



## **Education and Sport Development**

Department of Education and Sport Development  
Departement van Onderwys en Sportontwikkeling  
Lefapha la Thuto le Tihabololo ya Metshameko

**NORTH WEST PROVINCE**

**NATIONAL  
SENIOR CERTIFICATE**

**GRADE 12**

**PHYSICAL SCIENCES: PHYSICS (P1)**

**SEPTEMBER 2019**

**MARKS: 150**

**TIME: 3 hours**

**This question paper consists of 13 pages and 3 data sheets.**

**INSTRUCTIONS AND INFORMATION**

1. This question paper consists of 10 questions. Answer ALL the question in the ANSWER BOOK.
2. Start EACH question on a NEW page in the ANSWER BOOK.
3. Number the answers correctly according to the numbering system used in this question paper.
4. Leave ONE line between two sub questions, for example between QUESTION 2.1 and QUESTION 2.2.
5. You may use a non-programmable calculator.
6. You may use appropriate mathematical instruments.
7. You are advised to use the attached DATA SHEETS.
8. Show ALL formulae and substitutions in ALL calculations.
9. Round off your FINAL numerical answers to a minimum of TWO decimal places.
10. Give brief motivations, discussions, et cetera where required.
11. Write neatly and legibly.

**QUESTION 1: MULTIPLE-CHOICE QUESTIONS**

Various options are provided as possible answers to the following questions. Choose the answer and write only the letter (A–D) next to the question number (1.1–1.10) in the ANSWER BOOK, for example 1.11 D.

- 1.1 A car, mass  $m$  and a truck, mass  $3m$  collide head on. Just before impact, the car and the truck were moving at the same speed  $v$ . The car exerts a force  $F_C$  on the truck and the truck exerts a force  $F_T$  on the car. Choose the one statement that best describes the magnitude of the forces between the car and the truck on impact.



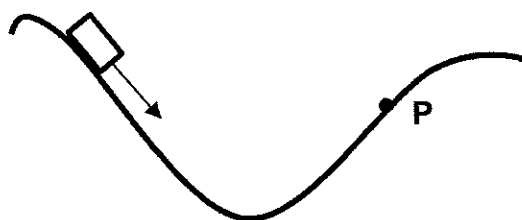

- A  $F_C = F_T$
- B  $F_C < F_T$
- C  $F_C = 0 \text{ N}$
- D  $F_C > F_T$

(2)

- 1.2 The diagram depicts a block sliding along a frictionless ramp.



In which direction is the block accelerating when it moves past point P.

- A 
- B 
- C 
- D 

(2)

- 1.3 A rocket is launched vertically upwards by a missile launcher. The velocity-time graph below depicts the motion of the rocket.

Indicate the point on the graph (1, 2, 3 or 4) where the rocket has maximum potential energy.

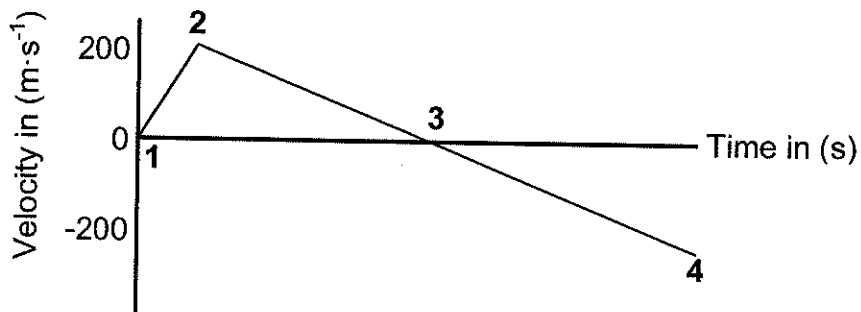

- A 1 (2)
- B 2
- C 3
- D 4 (2)

- 1.4 Dan pulls a block across a rough surface at a constant speed. The forces acting on the block are shown in the diagram below. The forces are not drawn to scale.

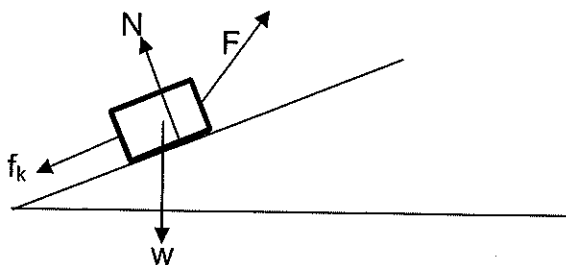

Which one of the following relationships regarding  $F$ ,  $f_k$ ,  $N$  and  $w$  are correct?

- A  $F = f_k$  and  $N = w$
- B  $F > f_k$  and  $N < w$
- C  $F < f_k$  and  $N > w$
- D  $F = f_k$  and  $N < w$  (2)

- 1.5 Using an inextensible rope of negligible mass, Ben pulls a box along a horizontal surface with a constant horizontal force  $F_A$ . The box moves at a constant velocity from position **A** to position **B**. A constant friction force  $f_k$  acts on the box.

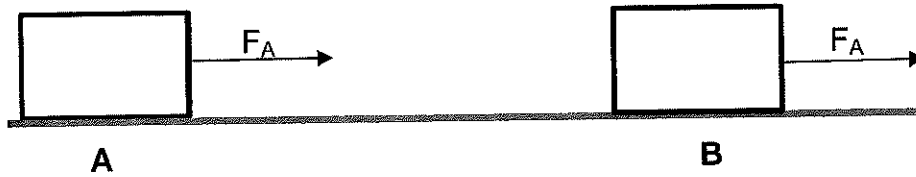

Which one of the following statements concerning the motion of the box from **A** to **B** is true?

- A The work done on the box by the gravitational force is not zero.
- B The total work done on the box by the net force is not zero.
- C The work done on the box by force  $f_k$  is positive.
- D The magnitude of the work done on the box by  $F_A$  is equal to the magnitude of the work done by  $f_k$ . (2)
- 1.6 Simon provides possible explanations about the observed shift of the light spectrum for light from a distant planet.
- Choose the CORRECT statement: Simon says that the ...
- A blue shift of the spectrum is an indication that the planet is moving towards the earth.
- B direction in which the planet moves has no influence on the spectrum.
- C red shift of the spectrum is an indication that the planet is moving towards the earth.
- D wind has an influence on the shift of the spectrum. (2)

- 1.7 Two small objects **P** and **R** carry charges  $+Q$  and  $+Q$  respectively. They exert a force  $\frac{1}{3}F$  on each other.



**R** is now charged to  $+6Q$  as shown in the diagram.



If the distance between **P** and **R** remains the same, what is the force on **P**?

- A  $3F$
- B  $2F$
- C  $F$
- D  $\frac{1}{3}F$

(2)

- 1.8 Two charges,  $+2\text{ C}$  and  $-2\text{ C}$ , are placed in fixed positions **A** and **B** respectively. A positive test charge is placed at position **C**.

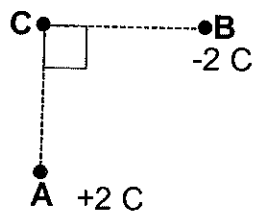

Which one of the following arrows indicates the direction of the nett electric field at point **C**?

- A
- B
- C
- D

(2)

- 1.9 Four identical resistors, each with a resistance  $R$ , are connected between points  $X$  and  $Y$  as indicated in the diagram.

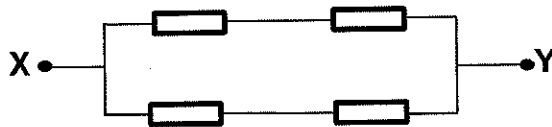

What is the equivalent resistance between  $X$  and  $Y$ ?

A  $R$

B  $2R$

C  $4R$

D  $\frac{1}{2}R$

(2)

- 1.10 An electron is released with a maximum speed of  $x \text{ m}\cdot\text{s}^{-1}$  from a metal surface when a photon of light hits the surface. If the electron has a mass of  $2y \text{ kg}$ , what will the work function of the metal be if the photon of light has an energy of  $4yx^2 \text{ J}$ .

A  $mx^2$

B  $2yx^2$

C  $\frac{1}{2}yx^2$

D  $3yx^2$

(2)

[20]

**QUESTION 2 (Start on a new page.)**

Peter is doing resistance training. Peter is running at a constant velocity of  $8 \text{ m}\cdot\text{s}^{-1}$  on a horizontal track. Peter exerts a force **F** on the rope tied to his waist. The rope is making an angle of  $14^\circ$  with the horizontal. He drags two large tyres, attached to each other with a light inextensible rope as shown in the diagram below. The mass of tyre **A** is 10 kg and the mass of tyre **B** is 15 kg.

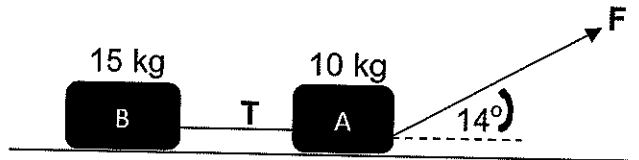

- 2.1 State Newton's First Law of Motion in words. (2)
- 2.2 Explain why the two tyres will have the same coefficient of friction. (2)
- 2.3 The kinetic friction coefficient between the tyres and the grass is 0,6.
- 2.3.1 Draw a labelled free body diagram of all the forces acting on tyre **B**. (4)
- 2.3.2 Calculate the magnitude of the frictional force on tyre **B**. (3)
- 2.3.3 Calculate the magnitude of force **F** applied by Peter. (6)
- 2.4 The rope between the tyres breaks unexpectedly.
- 2.4.1 Calculate the acceleration of tyre **B** directly after the rope breaks. (2)
- 2.4.2 State the work-energy theorem in words. (2)
- 2.4.3 Use the work-energy theorem to calculate how far tyre **B** will move before coming to rest. (4)

**[25]**



**QUESTION 3 (Start on a new page.)**

John, mass 80 kg, drops off the edge of a 75 m high tower with a strong elastic cord tied around his ankles. After falling a vertical distance of  $x$  m, he passes point **A** at a speed of  $31 \text{ m}\cdot\text{s}^{-1}$  just before the elastic cord starts slowing him down.

Ignore the mass of the rope and air resistance.

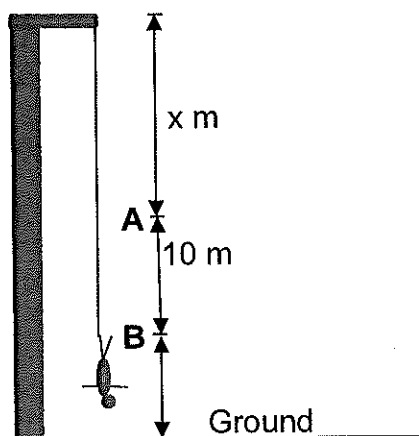

3.1 Explain the term free fall. (2)

3.2 Use equations of motions to calculate the distance  $x$  that John falls to reach his maximum velocity of  $31 \text{ m}\cdot\text{s}^{-1}$ . (3)

The rope stretches 10 m before John stops at point **B**, the lowest point of his movement. At the instant he stops, his camera (with negligible mass) drops out of his hands. The elastic cord pulls John back up. John passes point **A** with a speed of  $25 \text{ m}\cdot\text{s}^{-1}$  on his way up.

3.3 Calculate by using energy principals only, John's average acceleration on his way upwards from **B** to **A**. (4)

3.4 How long will it take John's camera to fall from point **B** to the ground? (5)

3.5 How high above the ground will John be the moment his camera hits the ground. (6)

3.6 John eventually comes to rest at a distance of 50 m below the top of the tower. John is pulled up by an electrical motor at a constant velocity of  $2 \text{ m}\cdot\text{s}^{-1}$ .

Calculate the average power of the motor. (3)

**[23]**

**QUESTION 4 (Start on a new page.)**

Tom, with a mass of 65 kg, slips on a mountain path and falls 5 m vertically downwards. Luckily, he lands on a 100 kg boat which is moving along a river directly below the path.

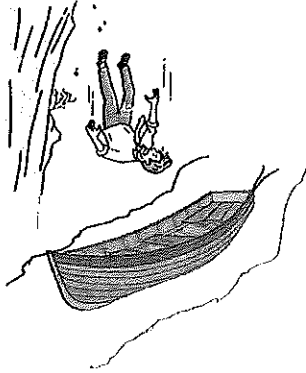

- 4.1 Define impulse. (2)
- 4.2 The boat was moving at a constant velocity of  $5 \text{ m}\cdot\text{s}^{-1}$  when Tom fell on it. Calculate the velocity of the boat and Tom directly after Tom fell on it. (5)

The boat collides with a rock in the river just after Tom fell into the boat. The boat comes to rest in 0,2 s.

- 4.3 Calculate the average force that the rock exerts on the boat. (4)
- [11]**

**QUESTION 5 (Start on a new page.)**

A sound source produces a sound of constant frequency, 384 Hz. The speed of sound in air is  $340 \text{ m}\cdot\text{s}^{-1}$  and the speed of sound in water is  $1500 \text{ m}\cdot\text{s}^{-1}$ .

- 5.1. Calculate the wavelength of the sound in air. (3)
- 5.2. How will the wavelength of the same sound in water compare with the wavelength in air? Choose from LONGER, SHORTER or THE SAME. (1)
- 5.3. What will happen to the frequency when a sound wave moves from air to water? Write down only INCREASES, DECREASES or REMAINS THE SAME. (1)

The same stationary sound source with a detector is used to determine the speed of a dolphin swimming at a constant velocity under water. It is found that the frequency received back from the dolphin is 391 Hz.

- 5.4 Is the dolphin swimming towards or away from the sound source? (1)
- 5.5 Calculate the speed of the dolphin. (6)
- [12]**

**QUESTION 6 (Start on a new page.)**

Three point charges, **X**, **Y** and **Z**, are placed in fixed positions as shown in the diagram below. The charges of **X** and **Y** are  $+3 \mu\text{C}$  and  $+2 \mu\text{C}$  respectively.

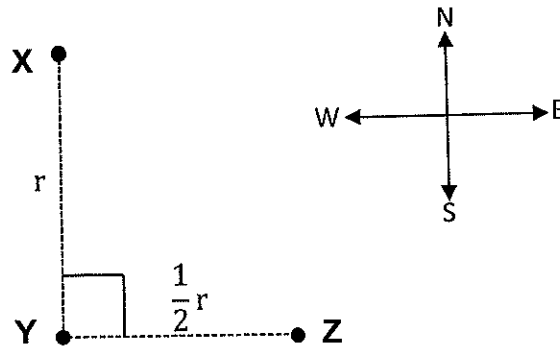

6.1 State Coulomb's law in words. (2)

6.2 **Y** experiences a net force of  $5 \times 10^{-3} \text{ N}$  in the direction  $32^\circ$  south east of the line joining charges **Y** and **Z**.

Calculate the:

6.2.1 Magnitude of the force exerted by **X** on **Y**. (2)

6.2.2 Magnitude and polarity of charge **Z**. (7)

[11]

**QUESTION 7 (Start on a new page.)**

In the diagram below the net electric field at a point **p** due to charges **V** and **W** is  $2 \times 10^{-2} \text{ NC}^{-1}$  to the right. The distance between **V** and **p** is 2 cm and between **p** and **W** is 3 cm. The magnitudes of charges **V** and **W** are equal.

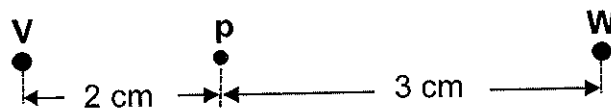

7.1 Determine the nature of the charge on **W** (only write POSITIVE or NEGATIVE). (1)

7.2 Draw the electric field lines around charge **W**. (3)

7.3 Define an electric field in words. (2)

7.4 Calculate the charge on **V**. (5)

[11]

**QUESTION 8 (Start on a new page.)**

A battery with a 12 V emf and  $1 \Omega$  internal resistance is connected in a circuit as shown below.

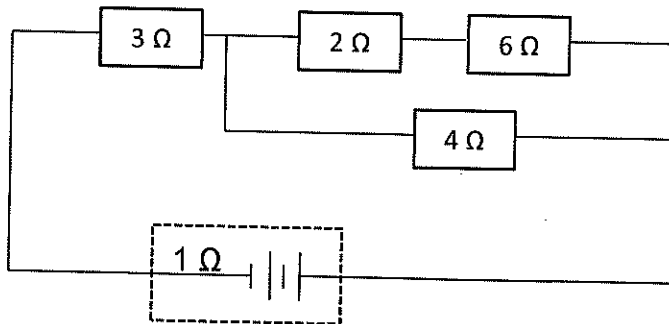

- 8.1. Define emf in words. (2)
- 8.2. Calculate the:
- 8.2.1 Total resistance of the circuit. (4)
- 8.2.2 Voltmeter reading across the  $4 \Omega$  resistor. (4)
- 8.2.3 Energy dissipated in the  $4 \Omega$  resistor in 2 minutes. (3)
- [13]**

**QUESTION 9 (Start on a new page.)**

The graph of potential difference versus time was obtained from an AC diesel generator. The frequency of the generator is 30 Hz.

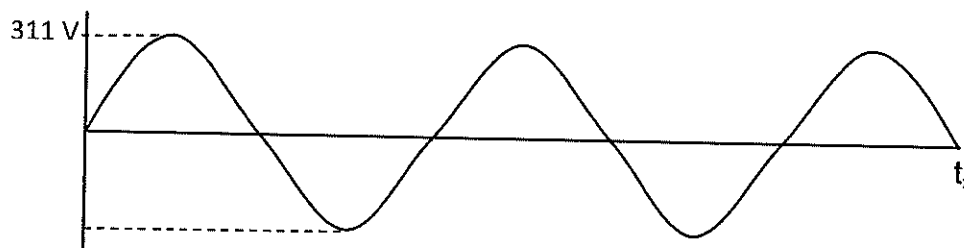

- 9.1 Calculate time  $t_x$  (3)
- 9.2 Define rms current ( $I_{rms}$ ). (2)
- The rms current is 12 A.
- 9.3 Calculate the average power produced by the generator. (4)
- 9.4 Calculate the peak current for this generator. (2)
- 9.5 Draw the corresponding current versus time graph for this generator. Clearly indicate the peak current and the time  $t_x$ . (3)
- [14]**

**QUESTION 10 (Start on a new page.)**

The spectrum below is observed when astronomers on earth analyse the light coming from planet X.

Alternating black and coloured lines



- 10.1 What is an atomic absorption spectrum. (2)
- 10.2 Identify the type of atomic spectrum above.  
(Choose between ABSORPTION or EMISSION spectrum). (1)
- 10.3 Radiation emitted on the planet with a wavelength of  $5,96 \times 10^{-7}$  m has a wavelength of  $6,0 \times 10^{-7}$  m when it reaches the earth.
- 10.3.1 Calculate the energy of a photon when it reaches the earth. (3)
- 10.3.2 The radiation is now shone onto a metal surface. What is the velocity of an electron leaving the surface of this metal if the metal has a work function of  $2,3 \times 10^{-19}$  J? (4)

**TOTAL:** [10]  
150

**DATA FOR PHYSICAL SCIENCES GRADE 12  
PAPER 1 (PHYSICS)**

**GEGEWENS VIR FISIESTE WETENSAPPE GRAAD 12  
VRAESTEL 1 (FISIKA)**

**TABLE 1: PHYSICAL CONSTANTS/TABEL 1: FISIESTE KONSTANTES**

NAME/NAAM	SYMBOL/SIMBOOL	VALUE/WAARDE
Acceleration due to gravity <i>Swaartekragversnelling</i>	g	9,8 m·s <sup>-2</sup>
Universal gravitational constant <i>Universele gravitasiekonstant</i>	G	6,67 x 10 <sup>-11</sup> N·m <sup>2</sup> ·kg <sup>-2</sup>
Mass of the Earth <i>Massa van die Aarde</i>	M	5,98 x 10 <sup>24</sup> kg
Radius of the Earth <i>Radius van die Aarde</i>	R <sub>E</sub>	6,38 x 10 <sup>6</sup> m
Speed of light in a vacuum <i>Spoed van lig in 'n vakuum</i>	c	3,0 x 10 <sup>8</sup> m·s <sup>-1</sup>
Planck's constant <i>Planck se konstante</i>	h	6,63 x 10 <sup>-34</sup> J·s
Coulomb's constant <i>Coulomb se konstante</i>	k	9,0 x 10 <sup>9</sup> N·m <sup>2</sup> ·C <sup>-2</sup>
Charge on electron <i>Lading op elektron</i>	e	1,6 x 10 <sup>-19</sup> C
Electron mass <i>Elektronmassa</i>	m <sub>e</sub>	9,11 x 10 <sup>-31</sup> kg

**TABLE 2: FORMULAE/TABEL 2: FORMULES****MOTION/BEWEGING**

$v_f = v_i + a \Delta t$	$\Delta x = v_i \Delta t + \frac{1}{2} a \Delta t^2$ or/of $\Delta y = v_i \Delta t + \frac{1}{2} a \Delta t^2$
$v_f^2 = v_i^2 + 2a \Delta x$ or/of $v_f^2 = v_i^2 + 2a \Delta y$	$\Delta x = \left( \frac{v_i + v_f}{2} \right) \Delta t$ or/of $\Delta y = \left( \frac{v_i + v_f}{2} \right) \Delta t$

**FORCE/KRAG**

$F_{\text{net}} = ma$	$p = mv$
$f_s^{\text{max}} = \mu_s N$	$f_k = \mu_k N$
$F_{\text{net}} \Delta t = \Delta p$ $\Delta p = mv_f - mv_i$	$w = mg$
$F = G \frac{m_1 m_2}{d^2}$ or/of $F = G \frac{m_1 m_2}{r^2}$	$g = G \frac{M}{d^2}$ or/of $g = G \frac{M}{r^2}$

**WORK, ENERGY AND POWER/ARBEID, ENERGIE EN DRYWING**

$W = F \Delta x \cos \theta$	$U = mgh$ or/of $E_p = mgh$
$K = \frac{1}{2} mv^2$ or/of $E_k = \frac{1}{2} mv^2$	$W_{\text{net}} = \Delta K$ or/of $W_{\text{net}} = \Delta E_k$ $\Delta K = K_f - K_i$ or/of $\Delta E_k = E_{kf} - E_{ki}$
$W_{\text{nc}} = \Delta K + \Delta U$ or/of $W_{\text{nc}} = \Delta E_k + \Delta E_p$	$P = \frac{W}{\Delta t}$
$P_{\text{ave}} = F v_{\text{ave}}$ / $P_{\text{gemid}} = F v_{\text{gemid}}$	

**WAVES, SOUND AND LIGHT/GOLWE, KLANK EN LIG**

$v = f \lambda$	$T = \frac{1}{f}$
$f_L = \frac{v \pm v_L}{v \pm v_s} f_s$ $f_L = \frac{v \pm v_L}{v \pm v_b} f_b$	$E = hf$ or/of $E = h \frac{c}{\lambda}$
$E = W_0 + E_{k(\text{max})}$ or/of $E = W_0 + K_{\text{max}}$ where/waar	
$E = hf$ and/en $W_0 = hf_0$ and/en $E_{k(\text{max})} = \frac{1}{2} mv_{\text{max}}^2$ or/of $K_{\text{max}} = \frac{1}{2} mv_{\text{max}}^2$	

**ELECTROSTATICS/ELEKTROSTATIKA**

$F = \frac{kQ_1Q_2}{r^2}$	$E = \frac{kQ}{r^2}$
$V = \frac{W}{q}$	$E = \frac{F}{q}$
$n = \frac{Q}{e}$ or/of $n = \frac{Q}{q_e}$	

**ELECTRIC CIRCUITS/ELEKTRIESE STROOMBANE**

$R = \frac{V}{I}$	emf ( $\mathcal{E}$ ) = $I(R + r)$ emk ( $\mathcal{E}$ ) = $I(R + r)$
$R_s = R_1 + R_2 + \dots$ $\frac{1}{R_p} = \frac{1}{R_1} + \frac{1}{R_2} + \dots$	$q = I \Delta t$
$W = Vq$ $W = VI \Delta t$ $W = I^2 R \Delta t$ $W = \frac{V^2 \Delta t}{R}$	$P = \frac{W}{\Delta t}$ $P = VI$ $P = I^2 R$ $P = \frac{V^2}{R}$

**ALTERNATING CURRENT/WISSELSTROOM**

$I_{rms} = \frac{I_{max}}{\sqrt{2}}$ / $I_{wgk} = \frac{I_{maks}}{\sqrt{2}}$	$P_{ave} = V_{rms} I_{rms}$ / $P_{gemiddeld} = V_{wgk} I_{wgk}$
$V_{rms} = \frac{V_{max}}{\sqrt{2}}$ / $V_{wgk} = \frac{V_{maks}}{\sqrt{2}}$	$P_{ave} = I_{rms}^2 R$ / $P_{gemiddeld} = I_{wgk}^2 R$
	$P_{ave} = \frac{V_{rms}^2}{R}$ / $P_{gemiddeld} = \frac{V_{wgk}^2}{R}$





## **Education and Sport Development**

Department of Education and Sport Development  
Departement van Onderwys en Sportontwikkeling  
Lefapha la Thuto le Tlhabololo ya Metshameko

**NORTH WEST PROVINCE**

**NATIONAL  
SENIOR CERTIFICATE  
NASIONALE  
SENIOR SERTIFIKAAT**

**GRADE/GRAAD 12**

**PHYSICAL SCIENCES: PHYSICS (P1)  
FISIESE WETENSKAPPE: FISIKA (V1)**

**SEPTEMBER 2019**

**MEMORANDUM**

**MARKS/PUNTE: 150**

**This memorandum consists of 7 pages./  
Hierdie memorandum bestaan uit 7 bladsye.**

**QUESTION 1/VRAAG 1**

- 1.1 A ✓ ✓
- 1.2 C ✓ ✓
- 1.3 C ✓ ✓
- 1.4 B ✓ ✓
- 1.5 D ✓ ✓
- 1.6 A ✓ ✓
- 1.7 B ✓ ✓
- 1.8 C ✓ ✓
- 1.9 A ✓ ✓
- 1.10 D ✓ ✓

[20]

**QUESTION 2**

2.1 A body will remain in its state of motion (at rest or moving at constant velocity) until a net force acts on it. ✓✓ / 'n Liggaam sal in sy toestand van beweging (in rus of beweging teen konstante snelheid) volhard, totdat 'n netto krag daarop inwerk. ✓✓ (2)

2.2 The two surfaces gliding across each other are the same (rubber and gras) ✓ / Die twee oppervalktes wat oor mekaar gly is dieselfde (rubber en gras) ✓ (2)

2.3.1

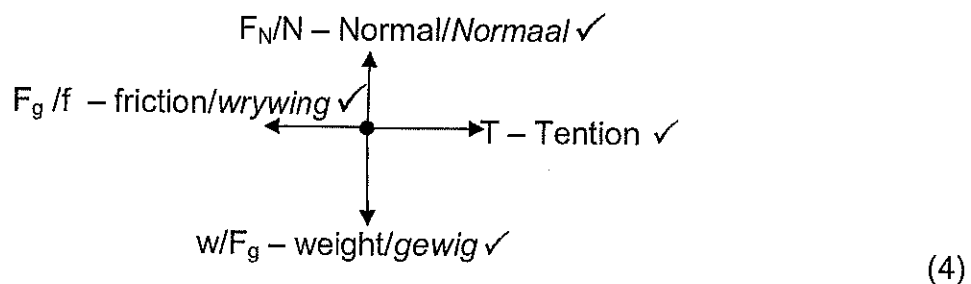

2.3.2  $f_k = \mu_k \cdot N$  ✓  
 $f_k = 0,6(15)(9,8)$  ✓  
 $f_k = \underline{88,2 \text{ N}}$  ✓ (3)

2.3.3 **+ marking from/nasien van 2.3.2**

$F_{\text{Net}} = ma$  ✓ = 0

**For B:**  $T = f_k$  ✓ ∴  $T = 88,2 \text{ N}$

**For A:**  $F_x = T + f_k$  ✓

$F \cdot \cos 14^\circ$  ✓ =  $88,2 + 0,6 \cdot 10 \cdot 9,8$  ✓

$F = \underline{151,5 \text{ N}}$  ✓ (6)

Downloaded from Stanmorephysics.com

2.4 2.4.1 + marking from/nasien van 2.3.2

$$F_{\text{Net}} = ma$$

$$88,2 = 15 \cdot a \checkmark$$

$$a = 5,88 \text{ m} \cdot \text{s}^{-2} \checkmark \quad (2)$$

2.4.2 The work done on an object by a net force is equal to the change in the object's kinetic energy  $\checkmark \checkmark$  / Die arbeid verrig op 'n voorwerp deur 'n netto krag is gelyk aan die verandering in kinetiese energie van die voorwerp.  $\checkmark \checkmark$

**Orlof**

The net work done on an object by a force is equal to the change in the object's kinetic energy  $\checkmark \checkmark$  / Die netto arbeid verrig op 'n voorwerp deur 'n krag is gelyk aan die verandering in kinetiese energie van die voorwerp.  $\checkmark \checkmark$  (2)

2.4.3 + marking from/nasien van 2.3.2

$$W_{\text{net}} = \Delta K = K_f - K_i \checkmark$$

$$-88,2 \cdot \Delta x \checkmark = \frac{1}{2} \cdot 15 \cdot 0 - \frac{1}{2} \cdot 15 \cdot 8^2 \checkmark$$

$$\Delta x = 5,44 \text{ m} \checkmark \quad (4)$$

**[25]****QUESTION 3**

3.1 Only force acting on the object is gravitational force (gravity)  $\checkmark \checkmark$  / Die enigste krag wat op die voorwerp inwerk is gravitasie krag.  $\checkmark \checkmark$  (2)

3.2  $v_f^2 = v_i^2 + 2 \cdot a \cdot \Delta y \checkmark$  Take downwards as +  
 $31^2 = 0 + 2 \cdot 9,8 \cdot \Delta y \checkmark$   
 $\Delta y = 49,03 \text{ m} \checkmark \quad (3)$

3.3  $W_{\text{net}} = m \cdot a \cdot \Delta x \cdot \cos \theta = \Delta K = K_f - K_i = \frac{1}{2} \cdot m \cdot v_f^2 - \frac{1}{2} \cdot m \cdot v_i^2 \checkmark$   
 $80 \cdot a \cdot 10 \cdot \cos 180^\circ \checkmark = \frac{1}{2} \cdot 80 \cdot 25^2 - \frac{1}{2} \cdot 80 \cdot 0 \checkmark$   
 $a = -31,25 \text{ m} \cdot \text{s}^{-2} \checkmark \quad (4)$

3.4 + marking from/nasien van 3.2  
 $\Delta y = 75 - 49,03 - 10 \checkmark = 15,97 \text{ m}$   
 $\Delta y = v_i \cdot \Delta t + \frac{1}{2} \cdot a \cdot \Delta t^2 \checkmark$   
 $15,97 \checkmark = 0 + \frac{1}{2} \cdot 9,8 \cdot \Delta t^2 \checkmark$   
 $\Delta t = 1,81 \text{ s} \checkmark \quad (5)$

3.5  $v_f = v_i + a \cdot \Delta t$   
 $25 = 0 + 31,25 \cdot \Delta t \checkmark$  Time in free fall =  $1,81 - 0,8 \checkmark$   
 $\Delta t = 0,8 \text{ s (Time for 10 m)}$  =  $1,01 \text{ s}$

$$\Delta y = v_i \cdot \Delta t + \frac{1}{2} \cdot a \cdot \Delta t^2 \checkmark$$

$$\Delta y = 25 \cdot 1,01 + \frac{1}{2} \cdot -9,8 \cdot 1,01^2 \checkmark$$

$$\Delta y = 20,25 \text{ m}$$

$$\Delta y \text{ of John from the ground} = 15,97 + 20,25 + 10 \checkmark = 46,22 \text{ m} \checkmark \quad (6)$$

3.6  $P = F \cdot v \checkmark = 80 \cdot 9,8 \cdot 2 \checkmark = 1568 \text{ W} \checkmark \quad (3)$

**[23]**

**QUESTION 4**

4.1 The product of the net force (acting on an object) and the time the (net) force acts (on the object) ✓✓ / Die produk van die netto krag wat op 'n voorwerp inwerk en die tyd wat die netto krag op die voorwerp inwerk. ✓✓ (2)

4.2  $\sum p \text{ before} = \sum p \text{ after}$  } ✓  
 $m_b \cdot v_i + m_T \cdot v_i = (m_b + m_T) \cdot v_f$  } ✓  
 $\frac{100 \cdot 5 + 65 \cdot 0}{100 + 65} = v_f$  ✓  
 $v_f = 3,03 \text{ m} \cdot \text{s}^{-1}$  ✓ In same direction as the original direction of boat ✓ (5)

4.3  $F_{\text{NET}} \cdot \Delta t = \Delta p$  ✓  
 $F_{\text{NET}} \cdot 0,2 = 165 (0 - 3,03)$  ✓  
 $F_{\text{NET}} = -2499,75$   
 $F_{\text{NET}} = 2499,75 \text{ N}$  ✓ in opposite direction as boat ✓ (4)  
**[11]**

**QUESTION 5**

5.1.  $v = \lambda \cdot f$  ✓  
 $340 = \lambda \cdot 384$  ✓  
 $\lambda = 0,89 \text{ m}$  ✓ (3)

5.2. Longer ✓ / Langer ✓ (1)

5.3. Remains the same ✓ / Bly dieselfde. ✓ (1)

5.4. Towards ✓ / Na ✓ (1)

5.5  $f_L = \frac{v \pm v_L}{v \pm v_s} \cdot f_s$  ✓  
 $f_L = \frac{1500 + v_L}{1500 - 0} \cdot 384$  ✓ ( $f_L$  become/word  $f_s$ )  
 $391 = \frac{1500}{1500 - v_s} \cdot \frac{1500 + v_L}{1500} \cdot 384$  ✓ ( $v_L = v_s$ )  
 $391 = \frac{1500}{1500 - x} \cdot \frac{1500 + x}{1500} \cdot 384$   
 $v = 13,55 \text{ m} \cdot \text{s}^{-1}$  ✓ (Range: 13,50 – 13,70) (6)  
**[12]**

**QUESTION 6**

6.1 The magnitude of the electrostatic force exerted by one point charge (Q1) on another point charge (Q2) is directly proportional to the product of the magnitudes of the charges and inversely proportional to the square of the distance (r) between them ✓✓ / Die grootte van die elektrostatiese krag wat een puntlading (Q1) op 'n ander puntlading (Q2) uitoefen, is direk eweredig aan die produk van die groottes van die ladings en omgekeerd eweredig aan die kwadraat van die afstand (r) tussen hulle. ✓✓ (2)

$$6.2.1 \quad F_{XY} = 5 \times 10^{-3} \cdot \cos 58^\circ \text{ (or } \sin 32^\circ) \checkmark = \underline{2,65 \times 10^{-3} \text{ N}} \checkmark \quad (2)$$

$$6.2.2 \quad F_{XY} = \frac{k \cdot Q_X \cdot Q_Y}{r^2} \checkmark$$

$$2,65 \times 10^{-3} \checkmark = \frac{9,0 \times 10^9 \cdot 3 \times 10^{-6} \cdot 2 \times 10^{-6}}{r^2} \checkmark$$

$$r = \underline{4,51 \text{ m}}$$

$$(\therefore \frac{1}{2}r = \underline{2,26 \text{ m}})$$

$$5 \times 10^{-3} \cdot \cos 32^\circ \text{ (or } \sin 58^\circ) \checkmark = \frac{9,0 \times 10^9 \cdot 2 \times 10^{-6} \cdot Q_Z}{2,26^2} \checkmark$$

$$Q_Z = \underline{-1,20 \times 10^{-6} \text{ C}} \checkmark \quad (7)$$

(mark polarity independent)

**[11]**

**QUESTION 7**

7.1 Negative/Negatief (1)

7.2

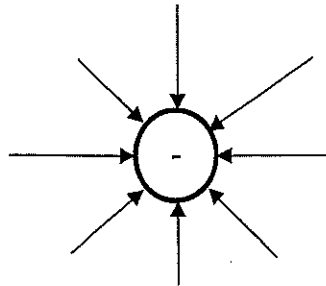

Negative	✓
Arrow direction	✓
Arrows touching charge	✓

(3)

7.3 A region of space in which an electric charge experiences a force ✓✓ / 'n Gebied in die ruimte waarin 'n elektriese lading 'n krag ondervind. ✓✓ (2)

$$7.4 \quad E_{\text{Net}} = E_V + E_W \checkmark$$

$$2 \times 10^{-2} \checkmark = \frac{9,0 \times 10^9 \cdot Q}{0,02^2} \checkmark + \frac{9,0 \times 10^9 \cdot Q}{0,03^2} \checkmark \quad (Q_V = Q_W)$$

$$Q = \underline{6,15 \times 10^{-16} \text{ C}} \checkmark$$

(5)

**[11]**

### QUESTION 8

- 8.1. The total amount of energy supplied (by the source) per coulomb charge or per unit charge/Die totale hoeveelheid energie (deur die bron) per coulomb of per eenheidslading. ✓✓ (2)

$$8.2.1 \quad \frac{1}{R_E} = \frac{1}{R_{1+2}} + \frac{1}{R_3} = \frac{1}{8} + \frac{1}{4} \checkmark = \frac{3}{8}$$

$$R_E = 2,67 \, \Omega$$

$$R_T = R_E + R_4 + R_r \checkmark = 2,67 + 3 + 1 \checkmark = \underline{6,67 \, \Omega} \checkmark \quad (4)$$

$$8.2.2 \quad I = \frac{V_{emf}}{R_T} = \frac{12}{6,67} \checkmark = \underline{1,8 \, A}$$

$$V = I \cdot R \checkmark = 1,8 \cdot 2,67 \checkmark = \underline{4,80 \, V} \checkmark \quad (4)$$

$$8.2.3 \quad W = \frac{V^2 \cdot \Delta t}{R} \checkmark = \frac{4,80^2 \cdot 120}{4} \checkmark = \underline{694,08 \, J} \checkmark$$

**or/of**

$$I = \frac{V}{R} = \frac{4,80}{4} = 1,20 \, A$$

$$\begin{aligned} W &= I^2 R \Delta t \checkmark \\ &= 1,2^2 \cdot 4 \cdot 120 \checkmark \\ &= 691,20 \, J \checkmark \end{aligned}$$

**or/of**

$$\begin{aligned} W &= V I \Delta t \checkmark \\ &= 4,80 \cdot 1,2 \cdot 120 \checkmark \\ &= 691,20 \, J \checkmark \end{aligned}$$

(3)  
[13]

**QUESTION 9**

9.1  $T = \frac{1}{f} = \frac{1}{30} \checkmark = 0,033 \text{ s}$   
 $0,033 \times 2,5 \checkmark = \underline{0,0825 \text{ s}} \checkmark$  (2)

9.2 The value of the direct current that dissipates power in a resistor/Die waarde van die gelykstroom wat drywing in 'n weerstand vrystel. (3)

9.3  $V_{\text{rms}} = \frac{V_{\text{max}}}{\sqrt{2}} = \frac{311}{\sqrt{2}} \checkmark = 219,91 \text{ V}$        $R = \frac{V}{I} = \frac{219,91}{12} \checkmark = 18,325 \Omega$

$P_{\text{av}} = V_{\text{rms}} \cdot I_{\text{rms}} \checkmark = 219,91 \cdot 12 \checkmark = \underline{2638,92 \text{ W}} \checkmark$

or/of  $P_{\text{av}} = \frac{V_{\text{rms}}^2}{R} \checkmark = \frac{219,91^2}{18,325} \checkmark = \underline{2639,04 \text{ W}} \checkmark$

or/of  $P_{\text{av}} = I_{\text{rms}}^2 R \checkmark = 12^2 \cdot 18,325 \checkmark = \underline{2638,8 \text{ W}} \checkmark$  (4)

9.4  $I_{\text{rms}} = \frac{I_{\text{max}}}{\sqrt{2}}$   
 $12 = \frac{I_{\text{max}}}{\sqrt{2}} \checkmark$   
 $I_{\text{max}} = 16,97 \text{ A} \checkmark$  (2)

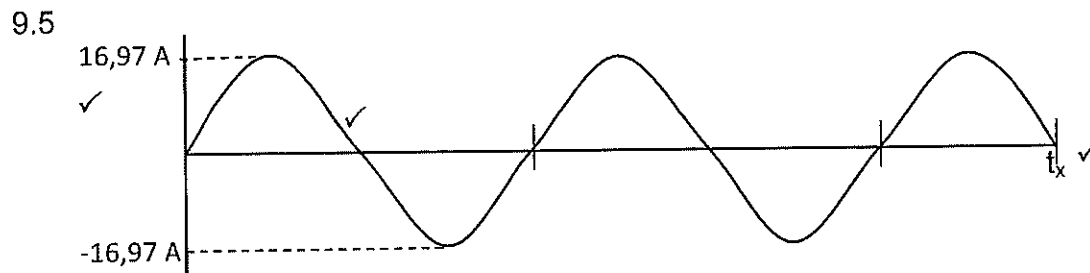

$I_{\text{max}}$ shown	<input checked="" type="checkbox"/>
Time interval (2,5 wave lengths)	<input checked="" type="checkbox"/>
Graph line (sinus graph)	<input checked="" type="checkbox"/>

(3)  
**[14]**

**QUESTION 10**

10.1 Absorption of specific wave lengths or frequencies of light when passing through a cold gas/Absorpsie spektrum van spesifieke golflengte of frekwensie van lig wat deur 'n koue gas beweeg.  $\checkmark \checkmark$  (2)

10.2 Emission (line) spectrum/emmissie spektrum  $\checkmark$  (1)

10.3.1  $E = \frac{hc}{\gamma} \checkmark = \frac{6,63 \times 10^{-34} \cdot 3 \times 10^8}{6,0 \times 10^{-7}} \checkmark = \underline{3,32 \times 10^{-19} \text{ J}} \checkmark$  (3)

10.3.2  $E = W_0 + E_k \checkmark$   
 $\frac{3,32 \times 10^{-19}}{v} \checkmark = 2,3 \times 10^{-19} + \frac{1}{2} \cdot 9,11 \times 10^{-31} \cdot v^2 \checkmark$  (4)  
 $v = \underline{4,72 \times 10^5 \text{ m} \cdot \text{s}^{-1}} \checkmark$  [10]

**TOTAL: 150**

**ANALYSIS GRID 2017 PHYSICAL SCIENCE P1**

Question No.	Taxonomy												Knowledge area				Question Totals			
	Content	Knowledge, Recall, Low Demand			COMPREHENSION, Basic Questions			APPLICATION, ANALYSIS, Problem Solving			SYNTHESIS, EVALUATION, Higher Abilities, Hard new problems, Challenge Level			TOTAL	MECHANICS	WAVES, SOUND & LIGHT		ELECTRICITY & MAGNETISM	MATTER & MATERIALS	TOTAL MARKS
		E	M	D	E	M	D	E	M	D	E	M	D		Marks					
1.1	force	2													2				2	
1.2	work						2								2				2	
1.3	energy					2									2				2	
1.4	momentum		2												2				2	
1.5	work						2								2				2	
1.6	sound				2											2			2	
1.7	charge		2														2		2	
1.8	fields					2											2		2	
1.9	electricity								2								2		2	
1.10	light											2						2	2	20
2.1	Newton's Law	2													2				2	
2.2	Newton's Law	2													1				2	
2.3.1	Newton's Law				4										4				4	
2.3.2	Newton's Law					3									3				3	
2.3.3	Newton's Law						6								6				6	
2.4.1	Newton's Law							3							3				3	
2.4.2	Energy							2							2				2	
2.4.3	Energy								4						4				4	25
3.1	projectile	2													2				2	
3.2	Projectile							3							3				3	
3.3	Energy									4					4				4	
3.4	Projectile								5						5				5	
3.5	Projectile											6			6				6	
3.6	Energy								3						3				3	23
4.1	momentum	2													2				2	
4.2	momentum								5						5				5	
4.5	momentum								4						4				4	11



5.1	Doppler	3												3		3				
5.2	Doppler						1							1		1				
5.3	Doppler						1							1		1				
5.4	Doppler		1											1		1				
5.5	Doppler													6		6	12			
6.1	electrostatics	2													2	2				
6.2.1	electrostatics				2										2	2				
6.2.2	electrostatics														7	7	11			
7.1	electrostatics					1									1	1				
7.2	electrostatics				3										3	3				
7.3	electrostatics	2													2	2				
7.4	electrostatics														5	5	11			
8.1	circuit		2												2	2				
8.2.1	circuit														4	4				
8.2.2	circuit														4	4				
8.2.3	circuit														3	3	13			
9.1	dynamics														3	3				
9.2	dynamics		2												2	2				
9.3	dynamics														4	4				
9.4	dynamics														2	2				
9.4	dynamics														3	3	14			
10.1	photoelectric		2													2	2			
10.2	photoelectric				1											1	1			
10.3.1	photoelectric															3	3			
10.3.2	photoelectric															4	4			
																	10			
															69	14	55	12	150	150
															69	14	55	12		
															46	9	36	8		
															%	%	%	%		
															45	3	36	10		
															%	%	%	%		
															15	35	40	10		

Overall

E	M	D
%	%	%
30	40	30