



education

Department of
Education
FREE STATE PROVINCE

PREPARATORY EXAMINATION

GRADE 12

**PHYSICAL SCIENCES P2
(CHEMISTRY)**

SEPTEMBER 2020

MARKS: 150

TIME: 3 HOURS

This question paper consists of 16 pages and 4 data sheets.

INSTRUCTIONS AND INFORMATION

1. Write your name and other applicable information in the appropriate spaces on the ANSWER BOOK.
2. The question paper consists of EIGHT questions. Answer ALL the questions in the ANSWER BOOK.
3. Start EACH question on a NEW page in the ANSWER BOOK.
4. Number the answers correctly according to the numbering system used in this question paper.
5. Leave ONE line between two subquestions, for example between QUESTION 2.1 and QUESTION 2.2.
6. You may use a non-programmable pocket calculator.
7. You may use appropriate mathematical instruments.
8. You are advised to use the attached DATA SHEETS.
9. Show ALL formulae and substitutions in ALL calculations.
10. Round off your FINAL numerical answers to a minimum of TWO decimal places where necessary.
11. Give brief motivations, discussions, et cetera where required.
12. Write neatly and legibly.

QUESTION 1: MULTIPLE-CHOICE QUESTIONS

Four options are provided as possible answers to the following questions. Choose the answer and write only the letter (A–D) next to the question number (1.1–1.10) in your ANSWER BOOK, for example 1.11 E.

1.1 C_2H_4 reacts with H_2 to produce a hydrocarbon as represented below.

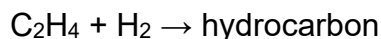

Which ONE of the following is the general formula of the hydrocarbon?

- A C_nH_{2n}
- B C_nH_{2n+1}
- C C_nH_{2n+2}
- D C_nH_{2n-2} (2)

1.2 The condensed structural formula of an organic compound is shown below.

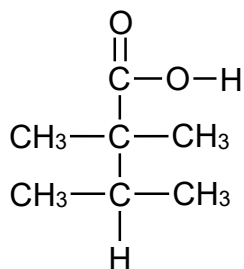

Which ONE of the following is the correct IUPAC name of this compound?

- A 2,2,3-trimethylbutanoic acid
- B 2,3,3-trimethylbutanoic acid
- C 2,2,3,3-tetramethylpropanoic acid
- D 1,1,2,2-tetramethylpropanoic acid (2)

1.3 Hydrogen bonds ...

- A are intramolecular forces.
- B are stronger intermolecular forces than chemical bonds.
- C form between hydrogen atoms in non-polar molecules.
- D form between molecules in which hydrogen atoms are bonded to highly electronegative atoms. (2)

1.4 The reaction of sulphur dioxide and oxygen to form sulphur trioxide reaches equilibrium in a closed container according to the following balanced equation:

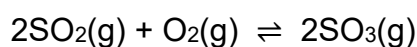

The graph below shows how the percentage yield of $\text{SO}_3(\text{g})$ at equilibrium changes with temperature.

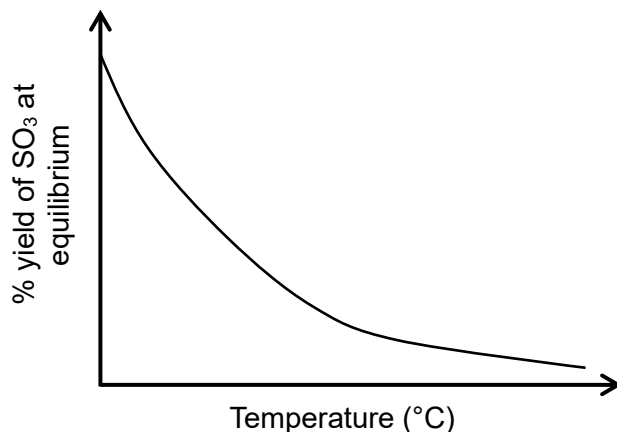

Which ONE of the following combinations is correct for the REVERSE REACTION?

	TYPE OF REACTION	HEAT OF REACTION (ΔH)
A	Exothermic	$E_{\text{SO}_2+\text{O}_2} - E_{\text{SO}_3}$
B	Endothermic	$E_{\text{SO}_3} - E_{\text{SO}_2+\text{O}_2}$
C	Exothermic	$E_{\text{SO}_3} - E_{\text{SO}_2+\text{O}_2}$
D	Endothermic	$E_{\text{SO}_2+\text{O}_2} - E_{\text{SO}_3}$

(2)

1.5 Which ONE of the following combinations is correct for an endothermic reaction?

	HEAT OF REACTION (ΔH)	THE POTENTIAL ENERGY OF PRODUCTS IS ...
A	positive	less than that of reactants.
B	positive	more than that of reactants.
C	negative	less than that of reactants.
D	negative	more than that of reactants.

(2)

1.6 The reaction of calcium carbonate with EXCESS dilute hydrochloric acid is used to investigate reaction rate. The balanced equation for the reaction is:



Two experiments, **I** and **II**, are conducted under different reaction conditions. The results obtained are represented in the graphs below.

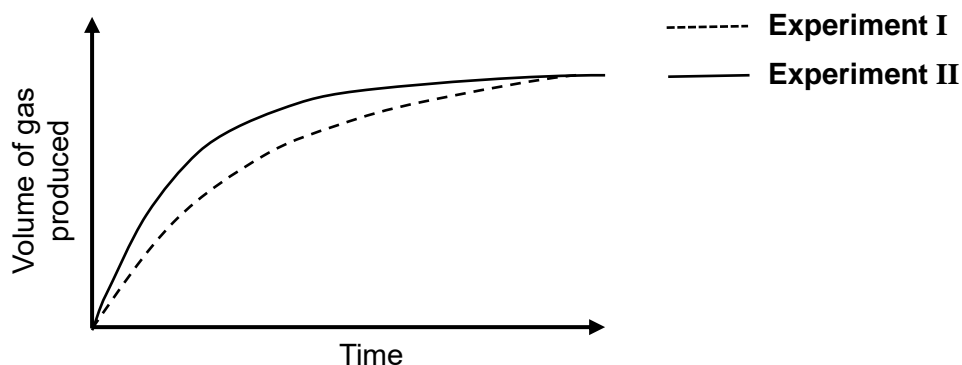

Which ONE of the statements below explains the difference in the above graphs the best?

In experiment **II**:

- A A greater volume of acid was used
- B More calcium carbonate was used
- C Acid of lower concentration was used
- D Calcium carbonate of larger surface area was used

(2)

1.7 Consider the following balanced equation for a reaction at equilibrium.



Which ONE of the following changes in temperature and pressure will result in the HIGHEST yield of solid?

	TEMPERATURE	PRESSURE
A	Decrease	Decrease
B	Decrease	Increase
C	Increase	Decrease
D	Increase	Increase

(2)

1.8 Which ONE of the following represents the products formed and the pH of the solution when ammonium chloride (NH_4Cl) undergoes hydrolysis?

	PRODUCTS FORMED	pH OF SOLUTION
A	$\text{HCl} + \text{OH}^-$	Above 7
B	$\text{NH}_3 + \text{OH}^-$	Below 7
C	$\text{NH}_4^+ + \text{OH}^-$	Above 7
D	$\text{NH}_3 + \text{H}_3\text{O}^+$	Below 7

(2)

1.9 The pH of the poison released when two different insects, **X** and **Y**, bite their prey, is given below.

Insect X: pH = 6

Insect Y: pH = 8

Which ONE of the following combinations gives the substances that will most probably bring relief from each of the insect bites?

	INSECT X	INSECT Y
A	Oxalic acid	Sodium hydroxide
B	Sodium hydrogen carbonate	Vinegar
C	Sodium hydroxide	Sodium hydrogen carbonate
D	Vinegar	Lemon juice

(2)

1.10 Consider the apparatus **P**, **Q**, **R** and **S** illustrated below.

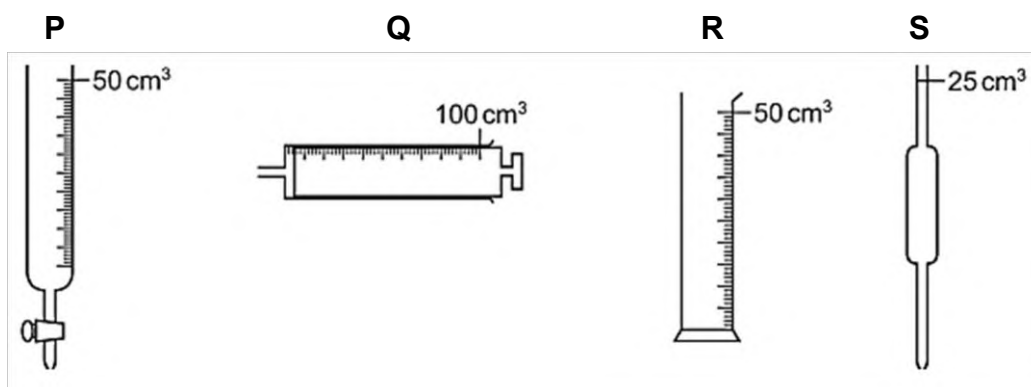

Which ONE of the following correctly links the above apparatus to the purpose for which it can be used?

	APPARATUS	PURPOSE
A	P	Measures the volume of acid added to base in a titration
B	Q	Measures the amount of calcium carbonate needed in a rate-determining experiment
C	R	Measures the volume of gas released in an experiment
D	S	Measures 15 cm ³ of base to be used in a titration

(2)

[20]

QUESTION 2 (Start on a new page.)

The letters **A** to **E** in the table below represent four organic compounds.

A	Ethanoic acid	B	C ₄ H ₁₀ O
C		D	
E	4-methylhex-2-yne	F	C ₈ H ₁₈

- 2.1 Compounds **A** and **B** are heated in the presence of an acid catalyst.
- Write down the:
- 2.1.1 Type of reaction that takes place (1)
- 2.1.2 Homologous series to which the organic product formed, belongs (1)
- 2.1.3 Structural formula of the organic product formed (2)
- 2.2 For compound **A**, write down the NAME of the:
- 2.2.1 Strongest intermolecular forces present (1)
- 2.2.2 Functional group (1)
- 2.3 Write down the GENERAL FORMULA of the homologous series to which compound **B** belongs. (1)
- 2.4 For compound **C**, write down the:
- 2.4.1 IUPAC name (2)
- 2.4.2 Structural formula of a FUNCTIONAL ISOMER of the SAME chain length (3)
- 2.5 Write down the IUPAC name of compound **D**. (3)

- 2.6 Consider compound **E**.
- 2.6.1 Is compound **E** a SATURATED or an UNSATURATED hydrocarbon?
Give a reason for the answer. (2)
- 2.6.2 Write down the structural formula of compound **E**. (3)
- 2.7 During a cracking reaction of compound **F**, ONE inorganic product and TWO organic products are formed. Prop-1-ene is one of the organic products formed.
- 2.7.1 Define the term *cracking reaction*. (2)
- 2.7.2 Write down TWO reaction conditions needed for thermal cracking to take place. (2)
- 2.7.3 Write down the IUPAC name of the other organic product formed. (2)
- 2.7.4 To which homologous series does the organic product in QUESTION 2.7.3 belong? (1)
- 2.7.5 Write down the NAME or FORMULA of the inorganic product formed. (1)

[28]

QUESTION 3 (Start on a new page.)

During a practical investigation, the boiling points of three compounds **A**, **B** and **C** were determined and the results recorded in the table below.

COMPOUND	HOMOLOGOUS SERIES	NUMBER OF C ATOMS	BOILING POINT (K)
A	Alkane	1	111,5
B	Alkane	2	184
C	Alcohol	2	351

- 3.1 Define the term *boiling point*. (2)
- 3.2 Write down the structural formula of the functional group of compound **C**. (1)
- 3.3 Is compound **C** a LIQUID or a GAS at 333 K? (1)
- 3.4 Which compound (**A**, **B** or **C**) has the highest vapour pressure?
Give a reason for the answer. (2)
- 3.5 During the investigation, the results obtained for the compounds above are compared.
- Write down the INDEPENDENT VARIABLE when comparing the results obtained for the following compounds:
- 3.5.1 Compounds **A** and **B** (1)
- 3.5.2 Compounds **B** and **C** (1)
- 3.6 Explain why compound **A** will evaporate faster than compound **B**. Refer to the TYPE and relative STRENGTHS of the intermolecular forces. (3)
- 3.7 Is it fair to compare compound **A** with compound **B**? Write only YES or NO. (1)
- 3.8 Give a reason for the answer to QUESTION 3.7 (1)

[13]

QUESTION 4 (Start on a new page.)

The flow diagram below shows how a haloalkane (compound **P**) can be used to prepare other organic compounds. The letters **A** to **F** represent different organic reactions.

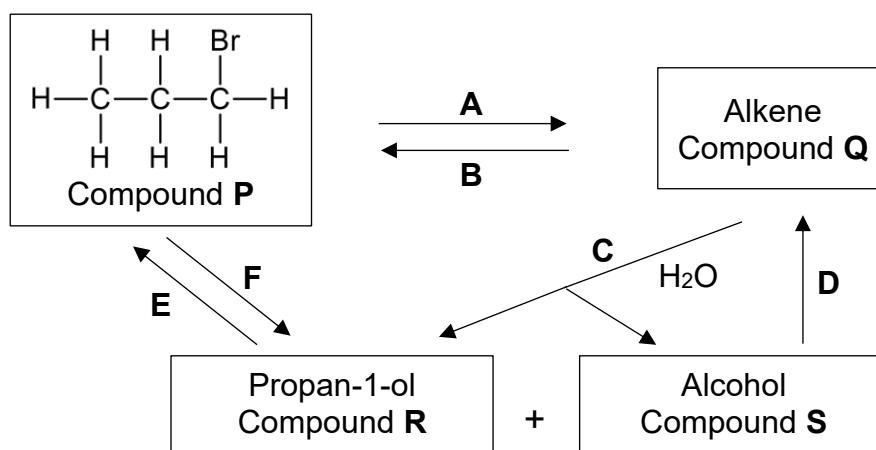

- 4.1 Is compound **P** a PRIMARY, SECONDARY or TERTIARY haloalkane? Give a reason for the answer. (2)
- 4.2 Write down the IUPAC name of compound **Q**. (1)
- 4.3 State TWO reaction conditions for reaction **F**. (2)
- 4.4 Compounds **R** and **S** are structural isomers.
- 4.4.1 Define the term *structural isomer*. (2)
- 4.4.2 Are compounds **R** and **S** POSITIONAL, FUNCTIONAL or CHAIN isomers? (1)
- 4.4.3 Give a reason for the answer to QUESTION 4.4.2. (1)
- 4.4.4 Write down the structural formula of compound **S**. (2)
- 4.5 Write down the name of:
- 4.5.1 Addition reaction **B** (1)
- 4.5.2 Elimination reaction **D** (1)
- 4.5.3 Substitution reaction **F** (1)
- 4.6 Using structural formulae, write down a balanced equation for reaction **E**. (4)

[18]

QUESTION 5 (Start on a new page.)

- 5.1 Learners use the reaction of magnesium powder with dilute hydrochloric acid in an experiment. The balanced equation for the reaction is:

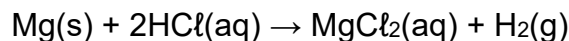

Initially, they add 250 cm³ hydrochloric acid (HCl) of concentration 0,3 mol·dm⁻³ to 1,2 g of magnesium powder in a test tube. The mass of the magnesium powder is recorded at regular time intervals. The sketch graph of mass against time below was obtained from the results.

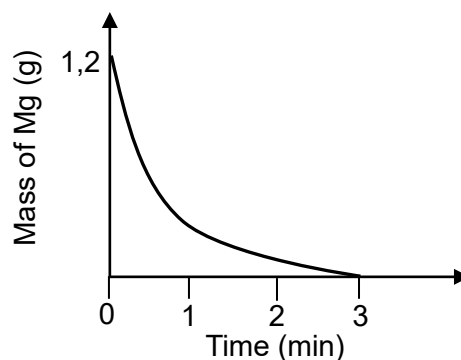

- 5.1.1 Define the term *reaction rate*. (2)
- 5.1.2 Write down the NAME or FORMULA of the limiting reagent in this reaction. Give a reason for the answer. (2)
- 5.1.3 Calculate the average rate of the reaction, in g·min⁻¹, in the first 2 minutes if the mass of the magnesium decreases by 1,1 g in this time. (3)
- 5.1.4 Calculate the number of moles of unreacted hydrochloric acid in the test tube after 3 minutes. (6)
- 5.1.5 Copy the axes and the curve above into your ANSWER BOOK and label it **A**. (No values are needed on the axes.)
- On the same set of axes, sketch curve **B** that will be obtained if a catalyst is added to the reaction mixture. (2)

- 5.2 The Maxwell-Boltzmann distribution curves, **P** and **Q**, for a reaction at two DIFFERENT TEMPERATURES are shown below. The vertical axis is not labelled.

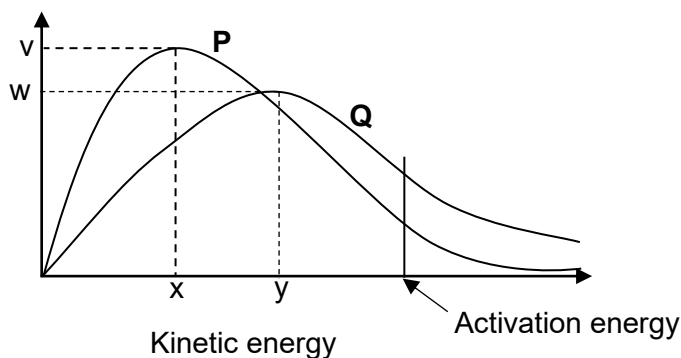

- 5.2.1 State the TWO criteria, as described by the collision theory, that should be met by any chemical reaction before it can take place. (2)
- 5.2.2 Write down a suitable label for the vertical axis shown above. (1)
- 5.2.3 Write down the letter (**v**, **w**, **x** or **y**) that indicates the most probable kinetic energy of molecules in the reaction mixture represented by curve **P**. (1)
- 5.2.4 Which curve, **P** or **Q**, represents the reaction taking place at the higher rate? Refer to the collision theory to explain the answer. (3)
- 5.2.5 How will the addition of a catalyst to the reaction mixture affect each of the following?

Write down INCREASE, DECREASE or REMAIN THE SAME.

- (a) The peak of curve **P** (1)
- (b) The number of molecules with energy equal to or greater than the activation energy (1)

[24]

QUESTION 6 (Start on a new page.)

The potential energy graph for the reaction of hydrogen with iodine is shown below.
The balanced equation for the reaction is:

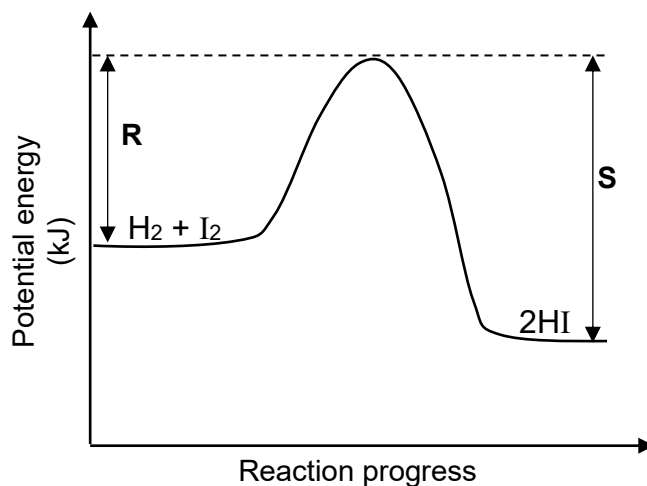
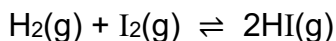

- 6.1 Is the forward reaction EXOTHERMIC or ENDOTHERMIC?
Give a reason for the answer. (2)
- 6.2 Define the term *activation energy*. (2)
- 6.3 In terms of **R** and **S** shown on the graph, write down an expression for the:
- 6.3.1 Activation energy for the forward reaction (1)
- 6.3.2 Heat of reaction (ΔH) for the forward reaction (1)

A catalyst is now added to the reaction mixture.

- 6.4 Redraw the above graph in your ANSWER BOOK and use a DOTTED LINE to show how the addition of a catalyst will influence the curve.
No labels are required. (2)
- 6.5 How will the catalyst affect the time taken by the reaction to reach equilibrium? Write down only INCREASES, DECREASES or REMAINS THE SAME. (1)

[9]

QUESTION 7 (Start on a new page.)

Excess sulphur and 3 mol oxygen gas are sealed in an empty 3 dm³ container at a certain temperature. The reaction reaches equilibrium according to the following balanced equation:

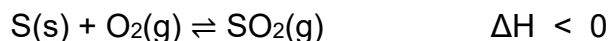

- 7.1 Define the term *chemical equilibrium*. (2)
- 7.2 The equilibrium constant (K_c) for the reaction at this temperature is 2.
- 7.2.1 Calculate the number of moles of $\text{SO}_2\text{(g)}$ present at equilibrium. (7)
- 7.2.2 Calculate the equilibrium concentration of $\text{SO}_2\text{(g)}$. (2)
- 7.3 How will each of the following affect the yield of $\text{SO}_2\text{(g)}$? Write down only INCREASES, DECREASES or REMAINS THE SAME.
- 7.3.1 More sulphur is added into the container. (1)
- 7.3.2 The pressure is increased by decreasing the volume of the container at constant temperature. (1)
- 7.4 The temperature is now changed and it is found that the equilibrium constant (K_c) increases. Did the temperature INCREASE or DECREASE? (1)
- 7.5 Explain the answer to QUESTION 7.4. (2)
- 7.6 How will the addition of a catalyst influence the equilibrium constant (K_c) of this reaction? Write down only INCREASES, DECREASES or REMAINS THE SAME. (1)
- [17]**

QUESTION 8 (Start on a new page.)

- 8.1 Sulphuric acid, H_2SO_4 , ionises in two steps. The first step in this ionisation is represented by the following incomplete equation.



- 8.1.1 Define the term *ampholyte*. (2)
- 8.1.2 For ampholyte **P**, write down the:
- (a) NAME or FORMULA (1)
- (b) NAME or FORMULA of its conjugate acid (1)
- (c) NAME or FORMULA of its conjugate base (1)

8.2 A $0,1 \text{ mol}\cdot\text{dm}^{-3}$ sodium hydroxide solution, $\text{NaOH}(\text{aq})$, is prepared in a 100 cm^3 volumetric flask. The sodium hydroxide solution is titrated with a $0,12 \text{ mol}\cdot\text{dm}^{-3}$ sulphuric acid solution, $\text{H}_2\text{SO}_4(\text{aq})$, using the apparatus illustrated below.

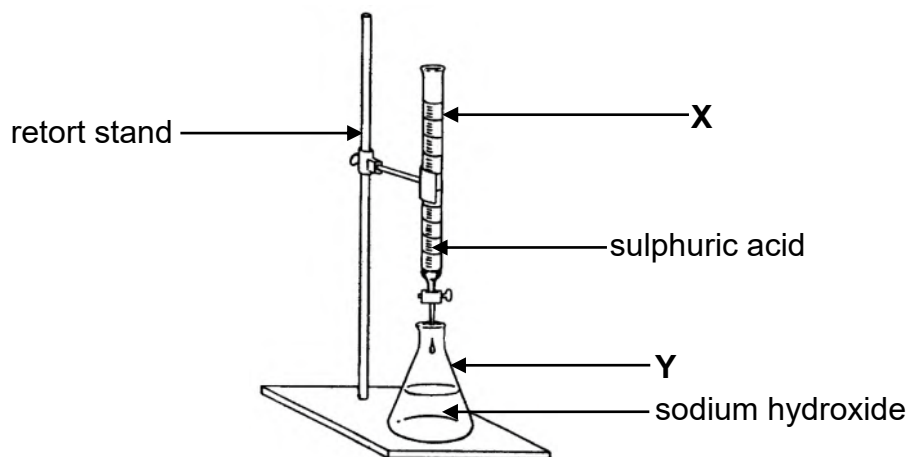

It is found that 15 cm^3 of the $\text{H}_2\text{SO}_4(\text{aq})$ neutralises an unknown volume of the $\text{NaOH}(\text{aq})$. The balanced equation for the reaction is:

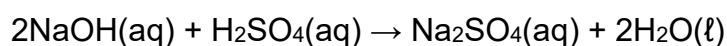

8.2.1 Define the term *strong base*. (2)

8.2.2 Write down the name of the apparatus labelled:

(a) **X** (1)

(b) **Y** (1)

8.2.3 Calculate the volume of sodium hydroxide that remains in **Y** after addition of 15 cm^3 sulphuric acid. (5)

8.3 The excess sodium hydroxide solution in **Y** reacts with $0,4 \text{ g}$ impure ammonium chloride, NH_4Cl , according to the following balanced equation:



Calculate the percentage impurities in the ammonium chloride. (7)
[21]

TOTAL: 150

**DATA FOR PHYSICAL SCIENCES GRADE 12
PAPER 2 (CHEMISTRY)**

**GEGEWENS VIR FISIESTE WETENSKAPPE GRAAD 12
VRAESTEL 2 (CHEMIE)**

TABLE 1: PHYSICAL CONSTANTS / TABEL 1: FISIESTE KONSTANTES

NAME / NAAM	SYMBOL / SIMBOOL	VALUE / WAARDE
Standard pressure <i>Standaarddruk</i>	p^θ	$1,013 \times 10^5 \text{ Pa}$
Molar gas volume at STP <i>Molêre gasvolume by STD</i>	V_m	$22,4 \text{ dm}^3 \cdot \text{mol}^{-1}$
Standard temperature <i>Standaardtemperatuur</i>	T^θ	273 K
Charge on electron <i>Lading op elektron</i>	e	$-1,6 \times 10^{-19} \text{ C}$
Avogadro's constant <i>Avodadro se konstante</i>	N_A	$6,02 \times 10^{23} \text{ mol}^{-1}$

TABLE 2: FORMULAE / TABEL 2: FORMULES

$n = \frac{m}{M}$	$n = \frac{N}{N_A}$
$c = \frac{n}{V}$ or/of $c = \frac{m}{MV}$	$n = \frac{V}{V_m}$
$\frac{c_a v_a}{c_b v_b} = \frac{n_a}{n_b}$	$\text{pH} = -\log[\text{H}_3\text{O}^+]$
$K_w = [\text{H}_3\text{O}^+][\text{OH}^-] = 1 \times 10^{-14} \text{ at/by } 298 \text{ K}$	
$E_{\text{cell}}^\theta = E_{\text{cathode}}^\theta - E_{\text{anode}}^\theta / E_{\text{sel}}^\theta = E_{\text{katode}}^\theta - E_{\text{anode}}^\theta$ or/of $E_{\text{cell}}^\theta = E_{\text{reduction}}^\theta - E_{\text{oxidation}}^\theta / E_{\text{sel}}^\theta = E_{\text{reduksie}}^\theta - E_{\text{oksidasie}}^\theta$ or/of $E_{\text{cell}}^\theta = E_{\text{oxidisingagent}}^\theta - E_{\text{reducingagent}}^\theta / E_{\text{sel}}^\theta = E_{\text{oksideermiddel}}^\theta - E_{\text{reduseermiddel}}^\theta$	

TABLE 4A: STANDARD REDUCTION POTENTIALS
TABEL 4A: STANDAARD-REDUKSIEPOTENSIALE

Half-reactions / Halfreaksies	E^θ (V)
$F_2(g) + 2e^- \rightleftharpoons 2F^-$	+ 2,87
$Co^{3+} + e^- \rightleftharpoons Co^{2+}$	+ 1,81
$H_2O_2 + 2H^+ + 2e^- \rightleftharpoons 2H_2O$	+1,77
$MnO_4^- + 8H^+ + 5e^- \rightleftharpoons Mn^{2+} + 4H_2O$	+ 1,51
$Cl_2(g) + 2e^- \rightleftharpoons 2Cl^-$	+ 1,36
$Cr_2O_7^{2-} + 14H^+ + 6e^- \rightleftharpoons 2Cr^{3+} + 7H_2O$	+ 1,33
$O_2(g) + 4H^+ + 4e^- \rightleftharpoons 2H_2O$	+ 1,23
$MnO_2 + 4H^+ + 2e^- \rightleftharpoons Mn^{2+} + 2H_2O$	+ 1,23
$Pt^{2+} + 2e^- \rightleftharpoons Pt$	+ 1,20
$Br_2(l) + 2e^- \rightleftharpoons 2Br^-$	+ 1,07
$NO_3^- + 4H^+ + 3e^- \rightleftharpoons NO(g) + 2H_2O$	+ 0,96
$Hg^{2+} + 2e^- \rightleftharpoons Hg(l)$	+ 0,85
$Ag^+ + e^- \rightleftharpoons Ag$	+ 0,80
$NO_3^- + 2H^+ + e^- \rightleftharpoons NO_2(g) + H_2O$	+ 0,80
$Fe^{3+} + e^- \rightleftharpoons Fe^{2+}$	+ 0,77
$O_2(g) + 2H^+ + 2e^- \rightleftharpoons H_2O_2$	+ 0,68
$I_2 + 2e^- \rightleftharpoons 2I^-$	+ 0,54
$Cu^+ + e^- \rightleftharpoons Cu$	+ 0,52
$SO_2 + 4H^+ + 4e^- \rightleftharpoons S + 2H_2O$	+ 0,45
$2H_2O + O_2 + 4e^- \rightleftharpoons 4OH^-$	+ 0,40
$Cu^{2+} + 2e^- \rightleftharpoons Cu$	+ 0,34
$SO_4^{2-} + 4H^+ + 2e^- \rightleftharpoons SO_2(g) + 2H_2O$	+ 0,17
$Cu^{2+} + e^- \rightleftharpoons Cu^+$	+ 0,16
$Sn^{4+} + 2e^- \rightleftharpoons Sn^{2+}$	+ 0,15
$S + 2H^+ + 2e^- \rightleftharpoons H_2S(g)$	+ 0,14
$2H^+ + 2e^- \rightleftharpoons H_2(g)$	0,00
$Fe^{3+} + 3e^- \rightleftharpoons Fe$	- 0,06
$Pb^{2+} + 2e^- \rightleftharpoons Pb$	- 0,13
$Sn^{2+} + 2e^- \rightleftharpoons Sn$	- 0,14
$Ni^{2+} + 2e^- \rightleftharpoons Ni$	- 0,27
$Co^{2+} + 2e^- \rightleftharpoons Co$	- 0,28
$Cd^{2+} + 2e^- \rightleftharpoons Cd$	- 0,40
$Cr^{3+} + e^- \rightleftharpoons Cr^{2+}$	- 0,41
$Fe^{2+} + 2e^- \rightleftharpoons Fe$	- 0,44
$Cr^{3+} + 3e^- \rightleftharpoons Cr$	- 0,74
$Zn^{2+} + 2e^- \rightleftharpoons Zn$	- 0,76
$2H_2O + 2e^- \rightleftharpoons H_2(g) + 2OH^-$	- 0,83
$Cr^{2+} + 2e^- \rightleftharpoons Cr$	- 0,91
$Mn^{2+} + 2e^- \rightleftharpoons Mn$	- 1,18
$Al^{3+} + 3e^- \rightleftharpoons Al$	- 1,66
$Mg^{2+} + 2e^- \rightleftharpoons Mg$	- 2,36
$Na^+ + e^- \rightleftharpoons Na$	- 2,71
$Ca^{2+} + 2e^- \rightleftharpoons Ca$	- 2,87
$Sr^{2+} + 2e^- \rightleftharpoons Sr$	- 2,89
$Ba^{2+} + 2e^- \rightleftharpoons Ba$	- 2,90
$Cs^+ + e^- \rightleftharpoons Cs$	- 2,92
$K^+ + e^- \rightleftharpoons K$	- 2,93
$Li^+ + e^- \rightleftharpoons Li$	- 3,05

Increasing oxidising ability / Toenemende oksiderende vermoë

Increasing reducing ability / Toenemende reduserende vermoë

TABLE 4B: STANDARD REDUCTION POTENTIALS
TABEL 4B: STANDAARD-REDUKSIEPOTENSIALE

Half-reactions / <i>Halfreaksies</i>	E^{θ} (V)
$\text{Li}^+ + \text{e}^- \rightleftharpoons \text{Li}$	-3,05
$\text{K}^+ + \text{e}^- \rightleftharpoons \text{K}$	-2,93
$\text{Cs}^+ + \text{e}^- \rightleftharpoons \text{Cs}$	-2,92
$\text{Ba}^{2+} + 2\text{e}^- \rightleftharpoons \text{Ba}$	-2,90
$\text{Sr}^{2+} + 2\text{e}^- \rightleftharpoons \text{Sr}$	-2,89
$\text{Ca}^{2+} + 2\text{e}^- \rightleftharpoons \text{Ca}$	-2,87
$\text{Na}^+ + \text{e}^- \rightleftharpoons \text{Na}$	-2,71
$\text{Mg}^{2+} + 2\text{e}^- \rightleftharpoons \text{Mg}$	-2,36
$\text{Al}^{3+} + 3\text{e}^- \rightleftharpoons \text{Al}$	-1,66
$\text{Mn}^{2+} + 2\text{e}^- \rightleftharpoons \text{Mn}$	-1,18
$\text{Cr}^{2+} + 2\text{e}^- \rightleftharpoons \text{Cr}$	-0,91
$2\text{H}_2\text{O} + 2\text{e}^- \rightleftharpoons \text{H}_2(\text{g}) + 2\text{OH}^-$	-0,83
$\text{Zn}^{2+} + 2\text{e}^- \rightleftharpoons \text{Zn}$	-0,76
$\text{Cr}^{3+} + 3\text{e}^- \rightleftharpoons \text{Cr}$	-0,74
$\text{Fe}^{2+} + 2\text{e}^- \rightleftharpoons \text{Fe}$	-0,44
$\text{Cr}^{3+} + \text{e}^- \rightleftharpoons \text{Cr}^{2+}$	-0,41
$\text{Cd}^{2+} + 2\text{e}^- \rightleftharpoons \text{Cd}$	-0,40
$\text{Co}^{2+} + 2\text{e}^- \rightleftharpoons \text{Co}$	-0,28
$\text{Ni}^{2+} + 2\text{e}^- \rightleftharpoons \text{Ni}$	-0,27
$\text{Sn}^{2+} + 2\text{e}^- \rightleftharpoons \text{Sn}$	-0,14
$\text{Pb}^{2+} + 2\text{e}^- \rightleftharpoons \text{Pb}$	-0,13
$\text{Fe}^{3+} + 3\text{e}^- \rightleftharpoons \text{Fe}$	-0,06
$2\text{H}^+ + 2\text{e}^- \rightleftharpoons \text{H}_2(\text{g})$	0,00
$\text{S} + 2\text{H}^+ + 2\text{e}^- \rightleftharpoons \text{H}_2\text{S}(\text{g})$	+0,14
$\text{Sn}^{4+} + 2\text{e}^- \rightleftharpoons \text{Sn}^{2+}$	+0,15
$\text{Cu}^{2+} + \text{e}^- \rightleftharpoons \text{Cu}^+$	+0,16
$\text{SO}_4^{2-} + 4\text{H}^+ + 2\text{e}^- \rightleftharpoons \text{SO}_2(\text{g}) + 2\text{H}_2\text{O}$	+0,17
$\text{Cu}^{2+} + 2\text{e}^- \rightleftharpoons \text{Cu}$	+0,34
$2\text{H}_2\text{O} + \text{O}_2 + 4\text{e}^- \rightleftharpoons 4\text{OH}^-$	+0,40
$\text{SO}_2 + 4\text{H}^+ + 4\text{e}^- \rightleftharpoons \text{S} + 2\text{H}_2\text{O}$	+0,45
$\text{Cu}^+ + \text{e}^- \rightleftharpoons \text{Cu}$	+0,52
$\text{I}_2 + 2\text{e}^- \rightleftharpoons 2\text{I}^-$	+0,54
$\text{O}_2(\text{g}) + 2\text{H}^+ + 2\text{e}^- \rightleftharpoons \text{H}_2\text{O}_2$	+0,68
$\text{Fe}^{3+} + \text{e}^- \rightleftharpoons \text{Fe}^{2+}$	+0,77
$\text{NO}_3^- + 2\text{H}^+ + \text{e}^- \rightleftharpoons \text{NO}_2(\text{g}) + \text{H}_2\text{O}$	+0,80
$\text{Ag}^+ + \text{e}^- \rightleftharpoons \text{Ag}$	+0,80
$\text{Hg}^{2+} + 2\text{e}^- \rightleftharpoons \text{Hg}(\ell)$	+0,85
$\text{NO}_3^- + 4\text{H}^+ + 3\text{e}^- \rightleftharpoons \text{NO}(\text{g}) + 2\text{H}_2\text{O}$	+0,96
$\text{Br}_2(\ell) + 2\text{e}^- \rightleftharpoons 2\text{Br}^-$	+1,07
$\text{Pt}^{2+} + 2\text{e}^- \rightleftharpoons \text{Pt}$	+1,20
$\text{MnO}_2 + 4\text{H}^+ + 2\text{e}^- \rightleftharpoons \text{Mn}^{2+} + 2\text{H}_2\text{O}$	+1,23
$\text{O}_2(\text{g}) + 4\text{H}^+ + 4\text{e}^- \rightleftharpoons 2\text{H}_2\text{O}$	+1,23
$\text{Cr}_2\text{O}_7^{2-} + 14\text{H}^+ + 6\text{e}^- \rightleftharpoons 2\text{Cr}^{3+} + 7\text{H}_2\text{O}$	+1,33
$\text{Cl}_2(\text{g}) + 2\text{e}^- \rightleftharpoons 2\text{Cl}^-$	+1,36
$\text{MnO}_4^- + 8\text{H}^+ + 5\text{e}^- \rightleftharpoons \text{Mn}^{2+} + 4\text{H}_2\text{O}$	+1,51
$\text{H}_2\text{O}_2 + 2\text{H}^+ + 2\text{e}^- \rightleftharpoons 2\text{H}_2\text{O}$	+1,77
$\text{Co}^{3+} + \text{e}^- \rightleftharpoons \text{Co}^{2+}$	+1,81
$\text{F}_2(\text{g}) + 2\text{e}^- \rightleftharpoons 2\text{F}^-$	+2,87



education

Department of
Education
FREE STATE PROVINCE

**PREPARATORY EXAMINATION
VOORBEREIDENDE EKSAMEN**

GRADE/GRAAD 12

**PHYSICAL SCIENCES P2: CHEMISTRY
FISIESE WETENSKAPPE V2: CHEMIE**

SEPTEMBER 2020

MARKS/PUNTE: 150

**MARKING GUIDELINES
NASIENRIGLYNE**

**These marking guidelines consist of 14 pages.
*Hierdie nasienriglyne bestaan uit 14 bladsye.***

QUESTION/VRAAG 1

- 1.1 C ✓✓ (2)
- 1.2 A ✓✓ (2)
- 1.3 D ✓✓ (2)
- 1.4 D ✓✓ (2)
- 1.5 B ✓✓ (2)
- 1.6 D ✓✓ (2)
- 1.7 B ✓✓ (2)
- 1.8 D ✓✓ (2)
- 1.9 B ✓✓ (2)
- 1.10 A ✓✓ (2)
- [20]**

QUESTION/VRAAG 2

- 2.1
- 2.1.1 Esterification/condensation ✓
Esterifikasie/verestering/ kondensasie (1)
- 2.1.2 Esters ✓ (1)

2.1.3

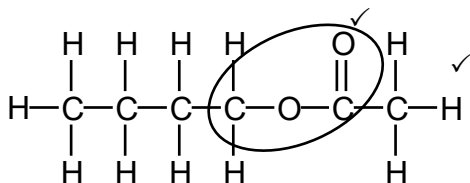

Marking criteria/Nasienkriteria:

- Whole structure correct/*Hele struktuur korrek:* 2/2
- Only functional group correct/*Slegs funksionele groep korrek:* 1/2

IF/INDIEN:

More than one functional group/*Meer as een funksionele groep:* 0/2

(2)

2.2

2.2.1 Hydrogen bonds/Waterstofbindings ✓ (1)

2.2.2 Carboxyl (group)/Karboksiel(groep) ✓ (1)

2.3 $C_nH_{2n+1}OH$ ✓ (1)

2.4

2.4.1 3-methylbutanal ✓/3-metielbutanaal (2)

2.4.2

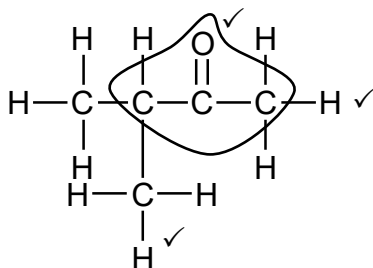

Marking criteria/Nasienkriteria:

- Functional group correct. ✓
Funksionele groep korrek.
- One methyl substituent. ✓
Een metiel substituent.
- Whole structure correct:

Hele struktuur korrek: 3/3

(3)

2.5 3-bromo-2-chloro-4-ethylhexane/3-bromo-2-chloro-4-etielheksaan

Marking criteria/Nasienkriteria:

- Correct stem, i.e. hexane./Korrekte stam d.i. heksaan. ✓
- All substituents (bromo, chloro and ethyl) correctly identified. ✓
Alle substituenten (bromo, chloro en etiel) korrek geïdentifiseer.
- IUPAC name completely correct including numbering, sequence, hyphens and commas. ✓
IUPAC-naam volledig korrek ingesluit nommering, volgorde, koppeltekens en kommas.

(3)

2.6

2.6.1 Unsaturated/Onversadig ✓

Has a triple bond/multiple bond between C atoms. ✓

Bevat 'n trippel/drievoudige/meervoudige binding tussen C-atome. (2)

2.6.2

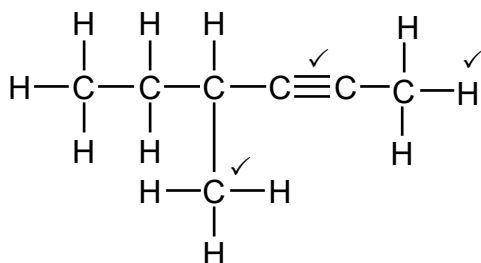

Marking criteria/Nasienkriteria:

- Functional group correct. ✓
Funksionele groep korrek.
- One methyl substituent. ✓
Een metiel substituent.
- Whole structure correct:

Hele struktuur korrek: 3/3

(3)

2.7

2.7.1

Marking guidelines/Nasienkriteria:

If any one of the underlined key phrases in the correct context is omitted, deduct 1 mark.

Indien enige van die onderstreepte frases in die korrekte konteks uitgelaat is, trek een punt af.

The (chemical) process in which longer chain hydrocarbons/longer chain alkanes are broken down to shorter or more useful hydrocarbons/molecules/chains/alkanes and alkenes.

Die (chemiese) proses waartydens langketting koolwaterstowwe/langketting alkane opgebreek word in korter of meer bruikbare koolwaterstowwe/molekule/kettings/alkane en alkene.

(2)

2.7.2 Heat/Hitte ✓

High pressure/Hoë druk ✓

(2)

2.7.3 pent-1-ene/1-pentene/pent-1-een/1-penteen ✓✓

OR/OF

pent-2-ene/2-pentene/pent-2-een/2-penteen

IF/INDIEN:

pentene/penteen

Max./Maks. 1/2

(2)

2.7.4 Alkenes/alkene ✓

(1)

2.7.5 Hydrogen/waterstof/H₂✓

(1)

[28]

QUESTION/VRAAG 3

3.1 The temperature at which the vapour pressure of a substance equals atmospheric pressure. ✓✓

Die temperatuur waarby die dampdruk van 'n stof gelyk is aan atmosferiese druk.

(2)

3.2 $\begin{array}{c} | \\ \text{---C---O---H} \\ | \end{array}$ ✓ **OR/OF** - O - H

(1)

3.3 Liquid/Vloeistof ✓

(1)

3.4 A ✓

Lowest boiling point/Weakest intermolecular forces ✓
Laagste kookpunt/Swakste intermolekulêre kragte

(2)

3.5

3.5.1 Number of C atoms/chain length/surface area ✓

Aantal C-atome/kettinglengte/oppervlak

(1)

3.5.2 Homologous series/type of compound/functional group ✓
Homoloë reeks/tipe verbinding/funksionele groep (1)

3.6

- Both compounds **A** and **B** have London/induced dipole forces/
dispersion forces. ✓
*Beide verbindings/A en B het Londonkragte/geïnduseerde dipool-
kragte/dispersiekragte.*
- Compound **B** has a larger surface area/longer chain length/more C
atoms than compound **A**. ✓
*Verbinding B het 'n groter oppervlakte/langer kettinglengte/meer
C-atome as verbinding A.*
- Intermolecular forces in compound **B** are stronger than those in
compound **A**. ✓
Intermolekulêre kragte in verbinding B is sterker as in verbinding A.

OR/OF

More energy needed to overcome intermolecular forces in compound **B**
than in compound **A**.
*Meer energie word benodig om intermolekulêre kragte in verbinding B
te oorkom as in verbinding A.*

OR/OF

Less energy needed to overcome intermolecular forces in compound **A**
than in compound **B**.
*Minder energie word benodig om intermolekulêre kragte in verbinding A
te oorkom as in verbinding B.* (3)

3.7 Yes/Ja ✓ (1)

3.8 Compounds **A** and **B** belong to the same homologous series/have
the same functional group. ✓
*Verbindings A en B behoort aan dieselfde homoloë reeks/het dieselfde
funksionele groep.*

OR/OF

Only one independent variable namely chain length.
Slegs een onafhanklike veranderlike naamlik kettinglengte. (1)
[13]

QUESTION/VRAAG 4

4.1 Primary/Primêre ✓



The C atom to which the Br atom is bonded is bonded to one other C atom. ✓

Die C-atoom waaraan die Br-atoom gebind is, is aan een ander C-atoom gebind. (2)

4.2 Propene/prop-1-ene/1-propene ✓
Propeen/prop-1-een/1-propeen (1)

4.3 Dilute strong base/NaOH/KOH/LiOH OR excess water ✓
Verdunde sterk basis/NaOH/KOH/LiOH OF oormaat water
(Mild) heat /*(Matige) hitte* ✓ (2)

4.4

4.4.1 Organic molecules with the same molecular formula, ✓ but different structural formulae. ✓
Organiese molekule met dieselfde molekulêre formule, maar verskillende struktuurformules. (2)

4.4.2 Positional (isomers)/*Posisie-(isomere)* ✓ (1)

4.4.3 **R** and **S** have the same molecular formula, but different positions of the functional group on the parent chain. ✓
R en S het dieselfde molekulêre formule, maar verskillende posisies van die funksionele groep op die moederketting. (1)

4.4.4

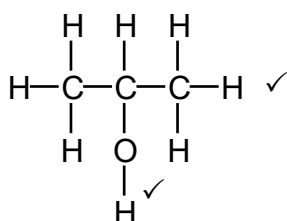

Marking criteria/Nasienkriteria:

- Whole structure correct/*Hele struktuur korrek:* 2/2
- Only functional group correct/*Slegs funksionele groep korrek:* 1/2

IF/INDIEN:

More than one functional group/*Meer as een funksionele groep:* 0/2

(2)

4.5

4.5.1 Hydrohalogenation/hydrobromination ✓
Hidrohalogenasie/hidrohalogenering/hidrobrominering/hidrobrominasie (1)

4.5.2 Dehydration/*Dehidrasie/dehidratering* ✓ (1)

4.5.3 Hydrolysis/*Hidrolise* ✓ (1)

4.6

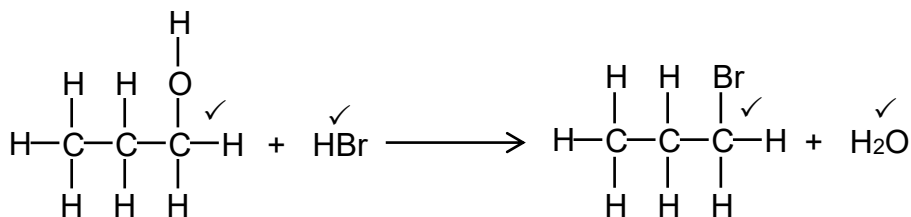

Marking criteria/Nasienkriteria

- Ignore/Ignoreer ⇒
- Accept coefficients that are multiples.
Aanvaar koëffisiënte wat veelvoude is.
- Any additional reactants and/or products
Enige addisionele reaktanse en/of produkte Max/Maks. 3/4
- Incorrect balancing/Verkeerde balansering: Max/Maks. 3/4
- Condensed formulae/Gekondenseerde formules:
 Max/Maks. 3/4
- Molecular formulae/Molekulêre formules: Max/Maks. 2/4

(4)
[18]

QUESTION/VRAAG 5

5.1

5.1.1 **ANY ONE/ENIGE EEN:**

- Change in concentration ✓ of a reactant/product per (unit) time. ✓
Verandering in konsentrasie van 'n reaktans/produk per (eenheids)tyd.
- Rate of change in concentration. ✓✓
Tempo van verandering in konsentrasie.
- Change in amount/number of moles/volume/mass ✓ of products/
 reactants per (unit) time. ✓
*Verandering in hoeveelheid/aantal mol/volume/massa van
 produkte/reaktanse per (eenheids)tyd.*
- Amount/number of moles/volume/mass of products formed OR
 reactants used ✓ per (unit) time. ✓
*Hoeveelheid/aantal mol/volume/massa van produkte gevorm OF
 reaktanse gebruik per (eenheids)tyd.*

NOTE/LET WEL:

Award mark for "per (unit) time" only in correct context.
Ken punt toe vir "per (eenheids)tyd" slegs in die korrekte konteks.

(2)

5.1.2 Magnesium/Mg ✓

Mg is used up./Mass of Mg after 3 minutes is 0 g. ✓

Mg is opgebruik./Massa van Mg na 3 minute is 0 g.

(2)

$$5.1.3 \text{ Rate/tempo} = -\frac{-1,1}{2-0} \checkmark$$

$$= 0,55 \text{ (g}\cdot\text{min}^{-1}) \checkmark$$

ACCEPT/AANVAAR:

$$\text{Rate/Tempo} = \frac{1,1}{2} \checkmark\checkmark = 0,55 \text{ (g}\cdot\text{min}^{-1}) \checkmark$$

(3)

5.1.4

Marking criteria/Nasienkriteria:

- Formula/Formule: $n = cV / n = \frac{m}{M} \checkmark$
- Substitute/Vervang $V = 250 \times 10^{-3}$ in $n = cV \checkmark$
- Substitute/Vervang $M = 24 \text{ g}\cdot\text{mol}^{-1}$ in $n = \frac{m}{M} \checkmark$
- Ratio/Verhouding: $n(\text{HCl}) : n(\text{Mg}) = 2 : 1 \checkmark$
- Subtraction/Aftrekking: $n(\text{HCl}_{\text{tot}}) - n(\text{HCl}_{\text{reacted/gereageer}}) \checkmark$
- Final answer/Finale antwoord: $0,025 \text{ mol} \checkmark$

$$n(\text{HCl}_{\text{tot}}) = cV \checkmark$$

$$= 0,5 \times 250 \times 10^{-3} \checkmark$$

$$= 0,125 \text{ mol}$$

$$n(\text{Mg}) = \frac{m}{M}$$

$$= \frac{1,2}{24} \checkmark$$

$$= 0,05 \text{ mol}$$

$$n(\text{HCl}_{\text{reacted/gereageer}}) = 2n(\text{Mg}) \checkmark$$

$$= 0,1 \text{ mol}$$

$$n(\text{HCl}_{\text{unreacted/ongereageer}}) = 0,125 - 0,1 \checkmark$$

$$= 0,025 \text{ mol} \checkmark$$

(6)

5.1.5

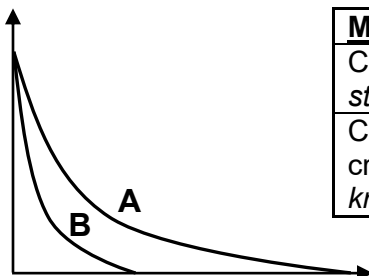

Marking criteria/Nasienkriteria:

Curve B steeper than curve A . /Kurwe B steiler as kurwe A .	✓
Curve B touches x-axis and curves do not cross. /Kurwe B raak die x-as en die kurwes kruis nie.	✓

(2)

5.2

5.2.1 Particles must have sufficient kinetic energy./Particles must have kinetic energy \geq activation energy. ✓

Deeltjies moet voldoende/genoeg kinetiese energie hê./Deeltjies moet kinetiese energie \geq aktiveringsenergie hê.

Particles should collide with correct orientation. ✓

Deeltjies moet met korrekte oriëntasie bots. (2)

5.2.2 Number/fraction/percentage of molecules ✓

Aantal/fraksie/persentasie van molekule (1)

5.2.3 x ✓

(1)

5.2.4 Q ✓

More molecules have sufficient kinetic energy./More molecules have kinetic energy equal to or greater than the activation energy. ✓

Meer molekule het voldoende kinetiese energie./Meer molekule het kinetiese energie gelyk aan en groter as die aktiveringsenergie.

More effective collisions per unit time./Meer effektiewe botsings per (eenheids)tyd. ✓

(3)

5.2.5

(a) Remains the same/*Bly dieselfde* ✓

(1)

(b) Increase/*Verhoog* ✓

(1)

[24]

QUESTION 6/VRAAG 6

6.1 Exothermic/Eksotermies ✓
 Energy of products lower than that of reactants./ Energy is released. ✓
Energie van produkte laer as dié van reaktanse./Energie is vrygestel. (2)

6.2 The minimum energy needed for a reaction to take place. ✓✓
Die minimum energie benodig vir 'n reaksie om plaas te vind. (2)

6.3

6.3.1 R ✓ (1)

6.3.2 $-(S - R)$ ✓ **OR/OF** $R - S$ **OR/OF** $-S + R$ (1)

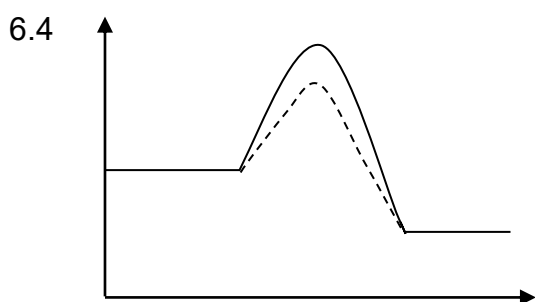

Marking criteria/Nasienkriteria:	
Dotted line starts at reactants and ends at products./ <i>Stippellyn begin by reaktanse en eindig by produkte.</i>	✓
Peak of dotted line lower than that of original curve./ <i>Piek van stippellyn laer as dié van oorspronklike kurwe.</i>	✓

(2)

6.5 Decreases/Verlaag ✓ (1)

[9]

QUESTION/VRAAG 7

7.1 The stage in a chemical reaction when the rate of the forward reaction equals the rate of the reverse reaction. ✓✓

Die stadium in 'n chemiese reaksie wanneer die tempo van die voorwaartse reaksie gelyk is aan die tempo van die terugwaartse reaksie.

OR/OF

The stage in a chemical reaction when the concentrations of reactants and products remain constant.

Die stadium in 'n chemiese reaksie wanneer die konsentrasies van die reaktanse en produkte konstant bly. (2)

7.2
7.2.1

USING NUMBER OF MOLES/GEbruik VAN AANTAL MOL
Marking criteria/Nasienkriteria:

- Ratio/Verhouding: $n(\text{O}_2)_{\text{change/verandering}} = n(\text{SO}_2)_{\text{change/verandering}} = x$ ✓
- $n(\text{O}_2)_{\text{eqm/ewe}} = n(\text{O}_2)_{\text{in/aanv.}} - n(\text{O}_2)_{\text{change/verandering}}$
and/en $n(\text{SO}_2)_{\text{eqm/ewe}} = n(\text{SO}_2)_{\text{change/verandering}}$ ✓
- Divide/Deel $n(\text{O}_2)_{\text{eqm/ewe}}$ & $n(\text{SO}_2)_{\text{eqm/ewe}}$ by/deur 3 dm^3 ✓
- Correct K_c expression/Korrekte K_c -uitdrukking ✓
- Substitution of K_c value/Vervanging van K_c -waarde ✓
- Substitution of concentrations into K_c expression ✓
Vervanging van konsentrasies in K_c -uitdrukking
- Final answer/Finale antwoord: 2 mol ✓

OPTION 1/OPSIE 1

	O ₂ (g)	SO ₂ (g)	
Initial quantity (mol) <i>Aanvanklike hoeveelheid (mol)</i>	3	0	
Change in quantity (mol) <i>Verandering in hoeveelheid (mol)</i>	x	x	✓
Quantity at equilibrium (mol) <i>Hoeveelheid by ewewig (mol)</i>	3 - x ✓	x	
Equilibrium concentration (mol·dm ⁻³) <i>Ewewigkonsentrasie (mol·dm⁻³)</i>	$\frac{3-x}{3}$	$\frac{x}{3}$	÷ 3 ✓

$$K_c = \frac{[\text{SO}_2]}{[\text{O}_2]} \quad \checkmark$$

$$2 \checkmark = \frac{x}{3-x} \quad \checkmark$$

$$x = 2 \text{ mol} \quad \checkmark$$

No K_c expression, correct substitution/Geen K_c -uitdrukking maar korrekte vervanging:
 Max./Maks. 6/7

Wrong K_c expression/Verkeerde K_c -uitdrukking:
 Max./Maks. 4/7

USING CONCENTRATION/GEBRUIK VAN KONSENTRASIE

Marking criteria/Nasienkriteria:

- Divide/Deel $n(\text{O}_2)_{\text{in}}$ by/deur 3 dm^3 ✓
- $c(\text{O}_2)_{\text{change/verandering}} = c(\text{SO}_2)_{\text{change/verandering}} = x$ ✓
- $c(\text{O}_2)_{\text{eqm/ewe}} = c(\text{O}_2)_{\text{in}} - c(\text{O}_2)_{\text{change/verandering}}$ &
 $c(\text{SO}_2)_{\text{eqm/ewe}} = c(\text{SO}_2)_{\text{change/verandering}}$ ✓
- Correct K_c expression/Korrekte K_c -uitdrukking ✓
- Substitution of K_c value/Vervanging van K_c -waarde ✓
- Substitution of concentrations into K_c expression ✓
Vervanging van konsentrasies in K_c -uitdrukking
- Final answer/Finale antwoord: 2 mol ✓

OPTION 2/OPSIE 2

	$\text{O}_2(\text{g})$	$\text{SO}_2(\text{g})$
Initial concentration ($\text{mol}\cdot\text{dm}^{-3}$) <i>Aanvanklike konsentrasie ($\text{mol}\cdot\text{dm}^{-3}$)</i>	$\frac{3}{3} = 1$ ✓	0
Change in concentration ($\text{mol}\cdot\text{dm}^{-3}$) <i>Verandering in konsentrasie ($\text{mol}\cdot\text{dm}^{-3}$)</i>	x	x ✓
Equilibrium concentration ($\text{mol}\cdot\text{dm}^{-3}$) <i>Ewewigskonsentrasie ($\text{mol}\cdot\text{dm}^{-3}$)</i>	$1 - x$	x ✓

$$K_c = \frac{[\text{SO}_2]}{[\text{O}_2]} \quad \checkmark$$

$$2 \checkmark = \frac{x}{1-x} \quad \checkmark$$

$$x = \frac{2}{3} \text{ mol}\cdot\text{dm}^{-3}$$

$$n(\text{SO}_2) = \frac{2}{3} \times 3 = 2 \text{ mol} \quad \checkmark$$

No K_c expression, correct substitution/Geen K_c -uitdrukking maar korrekte vervanging:
 Max./Maks. $\frac{6}{7}$

Wrong K_c expression/Verkeerde K_c -uitdrukking:
 Max./Maks. $\frac{4}{7}$

(7)

7.2.2 $c = \frac{2}{3} \checkmark$

$= 0,67 \text{ mol}\cdot\text{dm}^{-3} \checkmark$

(2)

7.3

7.3.1 Remains the same/Bly dieselfde ✓

(1)

7.3.2 Remains the same/Bly dieselfde ✓

(1)

7.4 Decrease/Verminder ✓

(1)

7.5 Increase in K_c implies that the forward reaction is favoured. ✓

Toename in K_c dui aan dat die voorwaartse reaksie bevoordeel is.

Decrease in temperature favours an exothermic reaction. ✓

Afname in temperatuur bevoordeel die eksotermiese reaksie.

(2)

7.6 Remains the same/Bly dieselfde ✓

(1)

[17]

QUESTION/VRAAG 8

8.1

8.1.1 A substance that can act as either acid or base. ✓✓
 'n Stof wat as suur of basis kan optree. (2)

8.1.2 (a) HSO_4^- /hydrogen sulphate (ion)/waterstofsulfaat(ioon) ✓ (1)

(b) H_2SO_4 /sulphuric acid/swawelsuur ✓ (1)

(c) SO_4^{2-} /sulphate (ion)/sulfaat(ioon) ✓ (1)

8.2

8.2.1 A base that dissociates/ionises completely ✓ in water ✓ to form a high concentration of OH^- ions.
 'n Basis wat volledig in water dissioseer/ioniseer om 'n hoë konsentrasie OH^- -ione te vorm. (2)

8.2.2 (a) Burette/Buret ✓ (1)

(b) Erlenmeyer flask/conical flask/Erlenmeyerfles/koniese fles ✓ (1)

8.2.3

<p>Marking criteria/Nasienkriteria:</p> <ul style="list-style-type: none"> Formula/Formule: $n = cV / \frac{n_a}{n_b} = \frac{c_a V_a}{c_b V_b}$ ✓ $0,12 \times 15 / 0,12 \times 15 \times 10^{-3}$ ✓ Ratio/Verhouding: $n_b = 2n_a$ ✓ $100 - V_b$ or/of $0,1 - V_b$ ✓ Final answer/Finale antwoord: 64 cm^3 or/of $0,064 \text{ dm}^3$ ✓ Range/Gebied: $0,06$ to $0,064 \text{ dm}^3$ 	
<p>OPTION 1/OPSIE 1</p> $\frac{n_a}{n_b} = \frac{c_a V_a}{c_b V_b} \checkmark$ $\frac{1}{2} \checkmark = \frac{0,12 \times 15}{0,1 \times V_b} \checkmark$ $V_b = 36 \text{ cm}^3 \text{ (0,036 dm}^3\text{)}$ <p>Excess/oormaat NaOH</p> $= \frac{100 - 36}{1} \checkmark$ $= 64 \text{ cm}^3 \checkmark$	<p>OPTION 2/OPSIE 2</p> $n_a = cV \checkmark$ $= 0,12 \times 15 \times 10^{-3} \checkmark$ $= 1,8 \times 10^{-3} \text{ mol}$ $n_b = 2n_a = 2 \times 1,8 \times 10^{-3} \checkmark$ $= 3,6 \times 10^{-3} \text{ mol}$ $n_b = cV$ $3,6 \times 10^{-3} = 0,1 \times V$ $V = 0,036 \text{ dm}^3$ <p>Excess/oormaat NaOH</p> $= \frac{0,1 - 0,036}{1} \checkmark$ $= 0,064 \text{ dm}^3 \checkmark$

(5)

8.3 **POSITIVE MARKING FROM QUESTION 8.2.3.**
POSITIEWE NASIEN VANAF VRAAG 8.2.3.

Marking criteria/Nasienkriteria:

- Formula/Formule: $n = cV / n = \frac{m}{M}$ ✓
- $0,1 \times 0,064$ ✓
- Ratio/Verhoudig: $n(\text{NH}_4\text{Cl}) = n(\text{NaOH})$ ✓
- Substitution of/Vervanging van $M = 53,5 \text{ g} \cdot \text{mol}^{-1}$ in $n = \frac{m}{M}$ ✓
- Calculate/Bereken % $\text{NH}_4\text{Cl}_{\text{pure/suiwer}}$ ✓
- $100 - \% \text{NH}_4\text{Cl}_{\text{pure/suiwer}}$ ✓
- Final answer/Finale antwoord = 14.4 % ✓

$$\begin{aligned}n(\text{NaOH}) &= cV \checkmark \\ &= 0,1 \times 0,064 \checkmark \\ &= 6,4 \times 10^{-3} \text{ mol} \\ n(\text{NH}_4\text{Cl}) &= n(\text{NaOH}) \checkmark = 6,4 \times 10^{-3} \text{ mol} \\ n(\text{NH}_4\text{Cl}_{\text{pure}}) &= \frac{m}{M} \\ 6,4 \times 10^{-3} &= \frac{m}{53,5} \checkmark \\ m &= 0,3424 \text{ g} \\ \% \text{NH}_4\text{Cl}_{\text{pure}} &= \frac{0,3424}{0,4} \times 100 \checkmark \\ &= 85,6\% \\ \% \text{NH}_4\text{Cl}_{\text{impure}} &= 100 - 85,6 \checkmark \\ &= 14,4 \% \text{ impurities/onsuiwerhede } \checkmark\end{aligned}$$

(7)
[21]

TOTAL/TOTAAL: 150