



basic education

Department:
Basic Education
REPUBLIC OF SOUTH AFRICA



**NATIONAL
SENIOR CERTIFICATE**

GRADE 12

**LIFE SCIENCES P1
NOVEMBER 2021**

MARKS: 150

TIME: 2½ hours



This question paper consists of 16 pages.

INSTRUCTIONS AND INFORMATION

Read the following instructions carefully before answering the questions.

1. Answer ALL the questions.
2. Write ALL the answers in the ANSWER BOOK.
3. Start the answers to EACH question at the top of a NEW page.
4. Number the answers correctly according to the numbering system used in this question paper.
5. Present your answers according to the instructions of each question.
6. Do ALL drawings in pencil and label them in blue or black ink.
7. Draw diagrams, tables or flow charts only when asked to do so.
8. The diagrams in this question paper are NOT necessarily drawn to scale.
9. Do NOT use graph paper.
10. You must use a non-programmable calculator, protractor and a compass, where necessary.
11. Write neatly and legibly.

SECTION A**QUESTION 1**

1.1

Various options are provided as possible answers to the following questions. Choose the answer and write only the letter (A to D) next to the question numbers (1.1.1 to 1.1.9) in the ANSWER BOOK, e.g. 1.1.10 D.

- 1.1.1 Grommets are used in the treatment of ...
- A deafness.
 - B blindness.
 - C middle-ear infection.
 - D multiple sclerosis.
- 1.1.2 The ability of the lens of the eye to change its shape when viewing an object that is near or far is called ...
- A binocular vision.
 - B accommodation.
 - C pupillary mechanism.
 - D refraction of light rays.
- 1.1.3 Which ONE of the following is the visual defect that results from the uneven curvature of the cornea?
- A Cataracts
 - B Long-sightedness
 - C Short-sightedness
 - D Astigmatism
- 1.1.4 The receptor(s) involved in maintaining balance is/are the ...
- A organ of Corti only.
 - B maculae only.
 - C maculae and cristae only.
 - D organ of Corti, maculae and cristae.
- 1.1.5 Which of the following structures are involved in maintaining balance when there is a change in the direction of movement of the body?
- A Semi-circular canals and cerebellum
 - B Eustachian tube and cerebellum
 - C Semi-circular canals and cerebrum
 - D Eustachian tube and cerebrum



1.1.6 Which of the following structures are protected by the meninges?

- A Spinal cord and receptors
- B Spinal cord and brain
- C Brain and effectors
- D Effectors and receptors

1.1.7 Two men were given a glucose-rich meal at the same time (0 hours). One man is diabetic and the other is non-diabetic. The diabetic did not receive any medical treatment. Their blood glucose levels were measured over a period of 3 hours.



The graphs below show the possible blood glucose levels of the two men during this time.

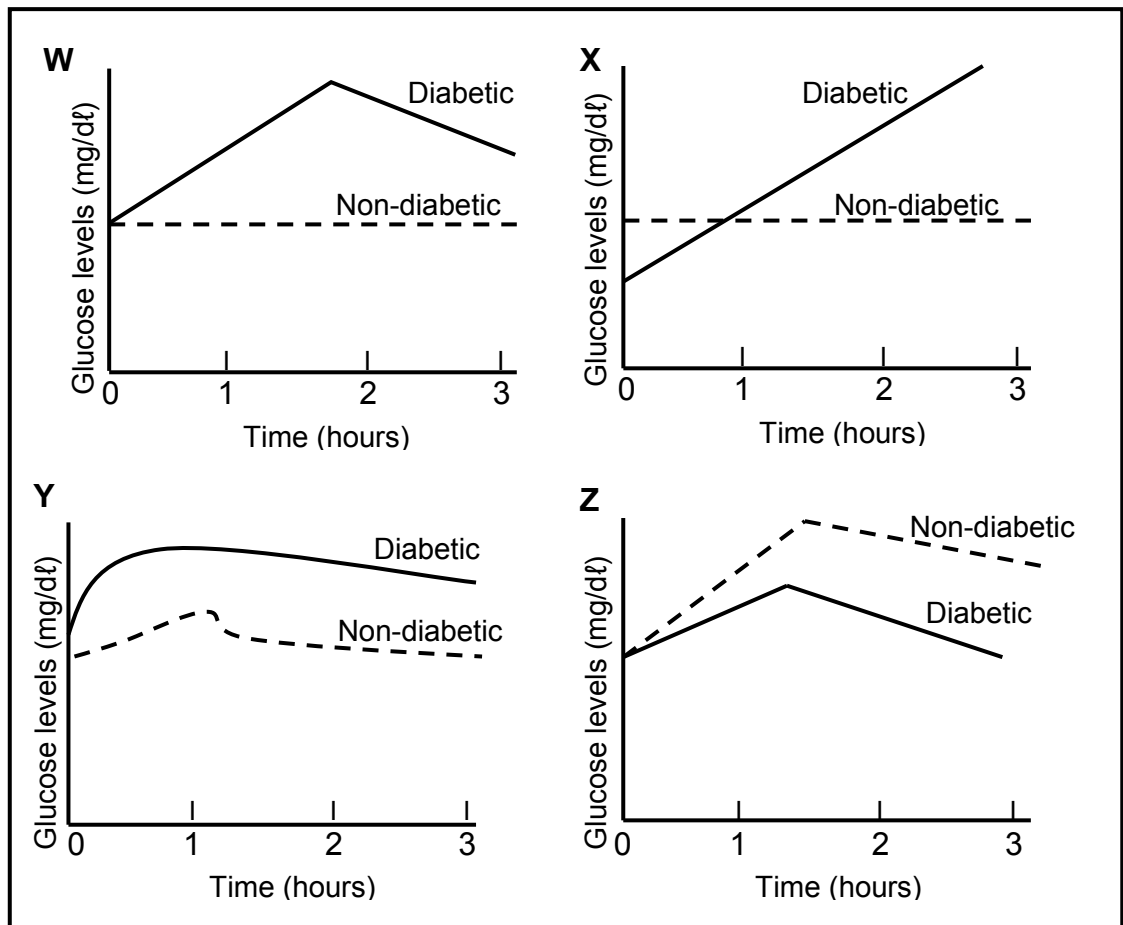

Which ONE of the graphs correctly represents the blood glucose levels of the two men?

- A W
- B X
- C Y
- D Z

1.1.8 During a reflex action, impulses enter the spinal cord by means of a/an ...

- A sensory neuron through the ventral root of the spinal nerve.
- B sensory neuron through the dorsal root of the spinal nerve.
- C interneuron through the ventral root of the spinal nerve.
- D interneuron through the dorsal root of the spinal nerve.

1.1.9 A person produces a smaller volume of urine most probably because ...

- A ADH levels are high in the blood and the renal tubules are more permeable to water.
- B ADH levels are high in the blood and the renal tubules are less permeable to water.
- C ADH levels are low in the blood and the renal tubules are more permeable to water.
- D ADH levels are low in the blood and the renal tubules are less permeable to water.

(9 x 2)

(18)

1.2 Give the correct **biological term** for each of the following descriptions. Write only the term next to the question number (1.2.1 to 1.2.8) in the ANSWER BOOK.

- 1.2.1 The release of an ovum from the ovary
- 1.2.2 The microscopic gap between two consecutive neurons
- 1.2.3 The period of development of the foetus in the uterus
- 1.2.4 The growth movement of a plant in response to a stimulus
- 1.2.5 The type of development in birds where the young are able to independently move and feed themselves after hatching
- 1.2.6 The extra-embryonic membrane that is responsible for the excretion of waste in an amniotic egg
- 1.2.7 Tubules in the testes where spermatogenesis occurs
- 1.2.8 The plant hormone that brings about seed dormancy when conditions are unfavourable (8 x 1) **(8)**

1.3 Indicate whether each of the descriptions in COLUMN I apply to **A ONLY**, **B ONLY**, **BOTH A AND B** or **NONE** of the items in COLUMN II. Write **A only**, **B only**, **both A and B** or **none** next to the question number (1.3.1 to 1.3.3) in the ANSWER BOOK.

| COLUMN I | | COLUMN II |
|----------|---|-------------------------------------|
| 1.3.1 | An exocrine gland | A: Cowper's gland B: Pancreas |
| 1.3.2 | A component of the peripheral nervous system | A: Cranial nerves B: Spinal cord |
| 1.3.3 | A disorder of the nervous system characterised by the degeneration of the brain cells | A: Goitre B: Alzheimer's disease |

(3 x 2) **(6)**



1.4 The diagram below shows the parts of the male reproductive system.

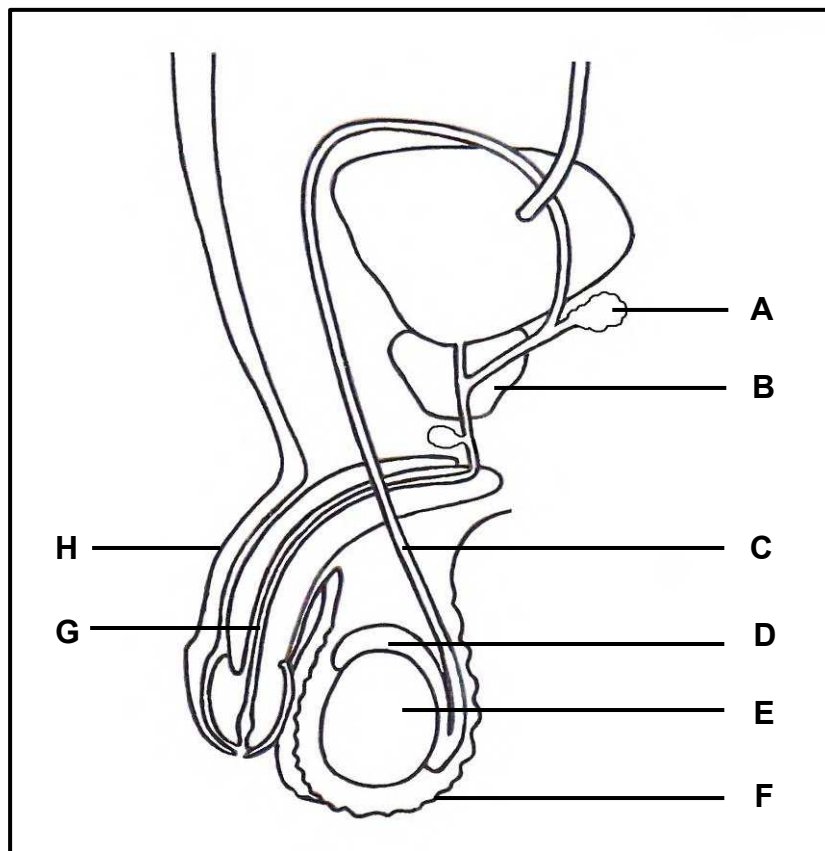

1.4.1 Identify part:

- (a) **C** (1)
- (b) **F** (1)
- (c) **H** (1)

1.4.2 Give the LETTER and NAME of the part that:

- (a) Stores sperm temporarily (2)
- (b) Transports both semen and urine (2)
- (c) Produces testosterone (2)

1.4.3 Give the LETTERS of TWO parts that contribute to the formation of semen.

(2)
(11)

1.5 The diagram below represents an ovum and a sperm.

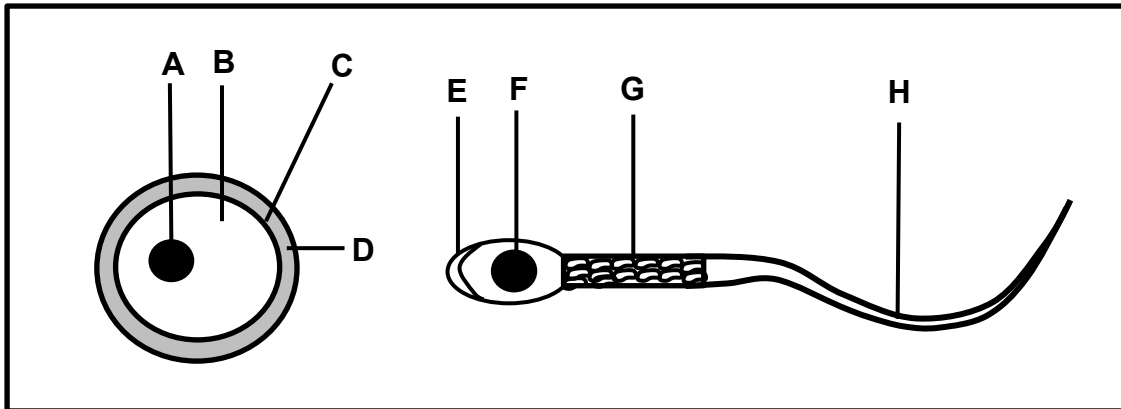

1.5.1 Identify part:

- (a) **B** (1)
- (b) **D** (1)
- (c) **H** (1)

1.5.2 Name the organelle found in large numbers in part **G**. (1)

1.5.3 Give the LETTERS of the TWO parts that fuse during fertilisation. (2)

1.5.4 Name the meiotic process whereby ova are produced. (1)
(7)

TOTAL SECTION A: 50

SECTION B

QUESTION 2

2.1 The diagram below represents a type of neuron found in the human body.

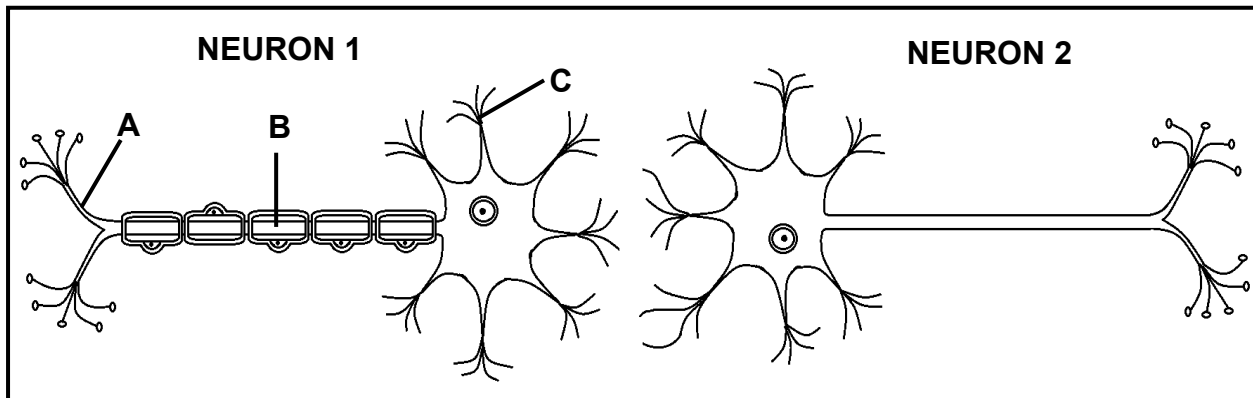

- 2.1.1 Identify the type of neuron shown. (1)
 - 2.1.2 Using the LETTERS **A**, **B** and **C** only, give the correct sequence for the transmission of an impulse along neuron 1. (2)
 - 2.1.3 Explain how the speed of transmission of impulses will differ for neuron 1 and neuron 2. (3)
 - 2.1.4 Explain why a person will feel the stimulus but will not be able to respond if only this type of neuron is damaged. (3)
- (9)**

2.2 The diagram below represents the structure of the human eye.

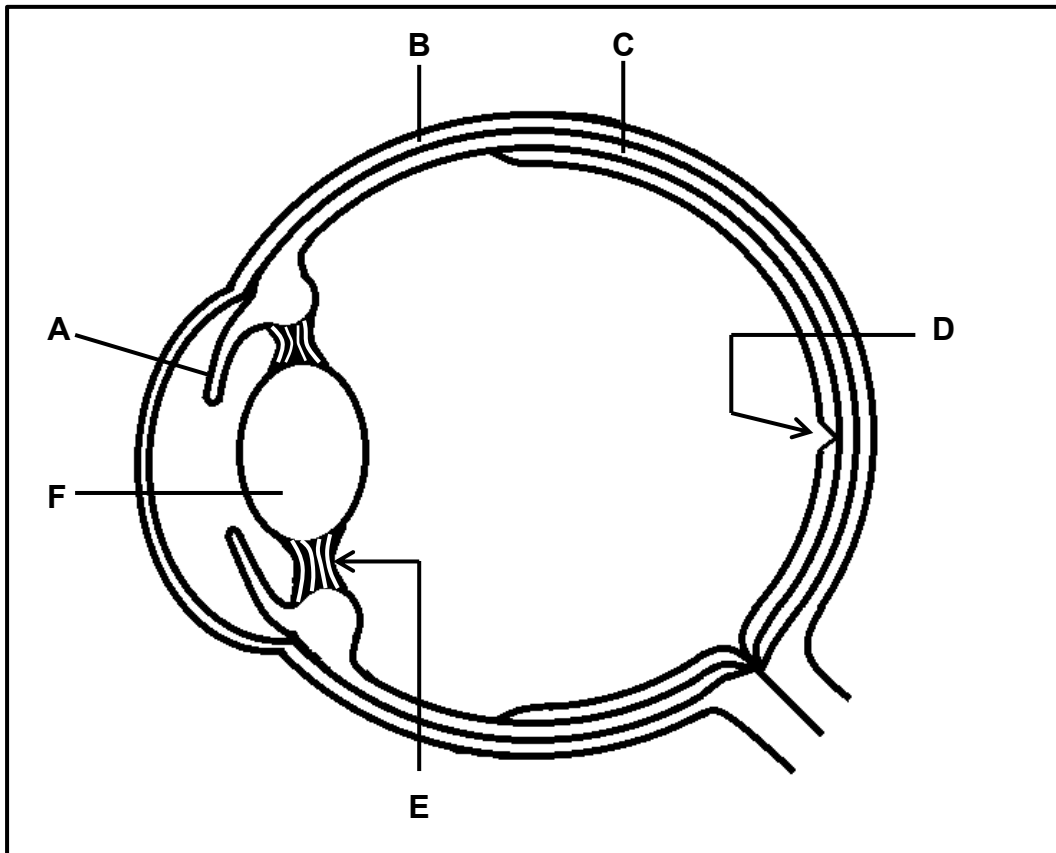

- 2.2.1 Identify part **C**. (1)
- 2.2.2 Give ONE function of part **E**. (1)
- 2.2.3 State why the clearest image will form when light rays fall on part **D**. (1)
- 2.2.4 Explain ONE way in which part **B** is structurally different from part **F**. (4)
- 2.2.5 Describe how the muscles in part **A** function to increase the amount of light entering the eye. (3)
- 2.2.6 Describe how a blurred image forms if a person with normal vision wears spectacles with biconvex lenses while reading a book. (3)
- (13)**

2.3 Read the extract below.

Endometriosis is a medical condition that occurs when the endometrium develops in or on other structures such as the Fallopian tubes, ovaries or pelvis. It is caused by higher than normal levels of oestrogen. Females with this condition will most likely experience mild to severe menstrual pains. This condition can sometimes lead to infertility.

Doctors may prescribe a contraceptive pill as treatment to reduce the development of the endometrium. The pill contains progesterone.

2.3.1 Name the structure where the endometrium normally develops. (1)

2.3.2 Explain why endometriosis in the Fallopian tubes may lead to infertility. (3)

2.3.3 Use the negative feedback mechanism to explain why the pills containing progesterone are successful in treating endometriosis. (4)
(8)

2.4 Describe the process of hearing. (7)

2.5 The diagram below shows a developing human foetus.

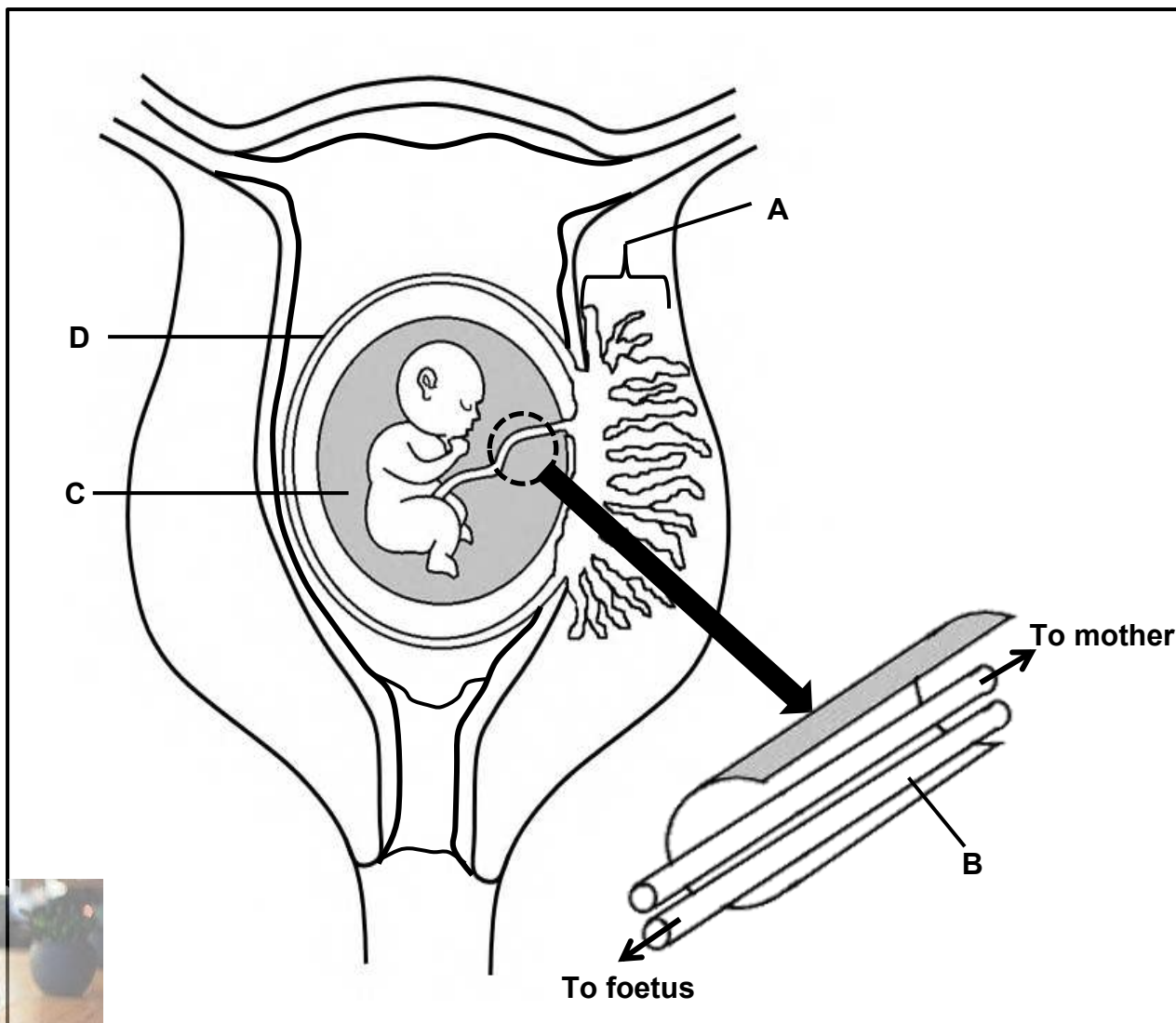

- 2.5.1 Identify part **D**. (1)
- 2.5.2 State TWO functions of the fluid in part **C**. (2)
- 2.5.3 Describe the development of the zygote until implantation occurs. (4)
- 2.5.4 State TWO ways in which part **A** functions in protecting the developing foetus. (2)
- 2.5.5 Identify blood vessel **B**. (1)
- 2.5.6 Describe how the nutrition of a human foetus differs from that of oviparous organisms. (3)

(13)
[50]

QUESTION 3

3.1 The diagrams below show the human brain and human kidney.

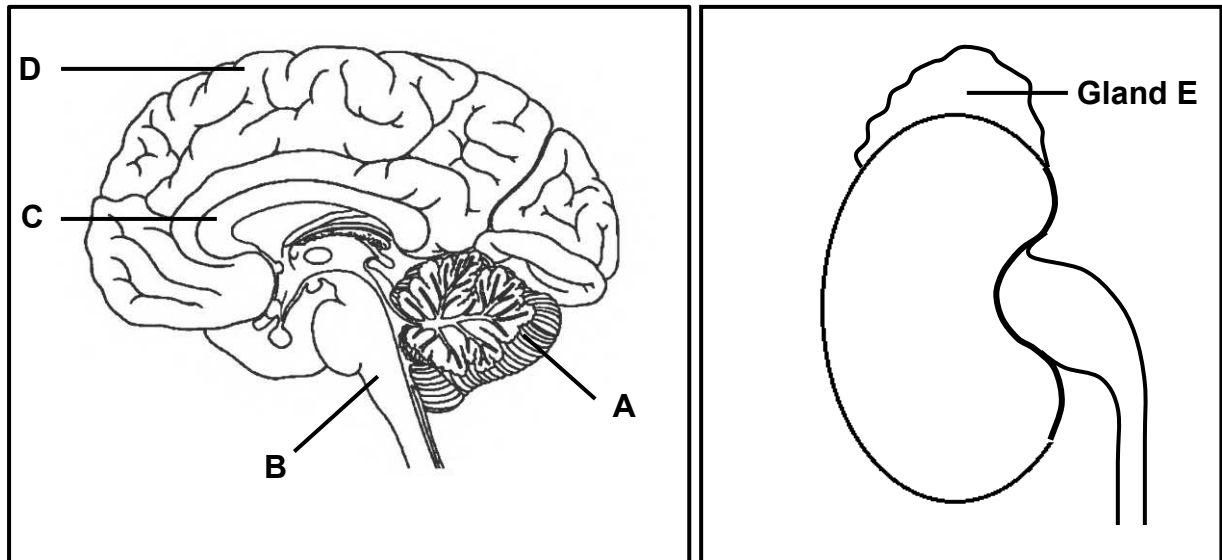

- 3.1.1 Identify part **A**. (1)
- 3.1.2 State ONE function of part **C**. (1)
- 3.1.3 A person sustained a head injury in a car accident and lost his memory.
Write down the LETTER and NAME of the part of the brain that was affected. (2)
- 3.1.4 During an emergency situation, gland **E** releases a hormone that prepares the body for a 'fight or flight' response by stimulating an increase in breathing rate and heart rate. This increase leads to increased energy production in the skeletal muscles and an increase in blood carbon dioxide levels.
- (a) Name the hormone secreted by gland **E** in an emergency situation. (1)
- (b) Explain how an increase in breathing rate and heart rate results in increased energy production in skeletal muscles. (4)
- (c) Describe how part **B** is involved in carbon dioxide homeostasis. (4)
- (13)**

3.2 The table below shows the average rate of blood flow to the skin at different environmental temperatures.

| ENVIRONMENTAL TEMPERATURE (°C) | AVERAGE RATE OF BLOOD FLOW TO THE SKIN (mℓ /100 mℓ tissue/min) |
|--------------------------------|--|
| 0 | 2,5 |
| 5 | 4 |
| 20 | 4,5 |
| 35 | 11 |
| 45 | 18 |
| 50 | 19 |

3.2.1 Give the environmental temperature at which there was the greatest average rate of blood flow to the skin. (1)

3.2.2 Describe the relationship between the environmental temperature and the average rate of blood flow to the skin. (2)

3.2.3 Calculate the percentage increase in blood flow to the skin between 5 °C and 35 °C. Show ALL your workings. (3)

3.2.4 Explain the average rate of blood flow to the skin between 20 °C and 45 °C. (4)

3.2.5 Frostbite is a condition where long term exposure to extremely cold conditions (0 °C or less) leads to the death of tissue in areas like the hands and feet.

Use the data from the table to explain why tissue may die. (2)
(12)

3.3 3.3.1 Describe the negative feedback mechanism that occurs when thyroxin levels in the blood are high. (5)

3.3.2 A person has a medical condition that results in the under-secretion of thyroxin.

Explain why this person will gain weight if the thyroxin levels remain continuously low in the blood. (3)
(8)

3.4 A group of learners conducted an investigation to determine the effect of auxins on the growth of stems in bean seedlings.

The procedure was as follows:

- 30 bean seeds were allowed to germinate for 5 days to produce seedlings.
- The seedlings were divided into 3 groups (**A**, **B** and **C**) of 10 seedlings each.
- The tips of all the seedlings were cut at the same length.
- In group **A**, the cut tip was placed back on top of the young stem.
- In group **B**, the tip was not placed back.
- In group **C**, a piece of plastic was placed on top of the cut surface and the tip was then placed on top of the plastic.
- The seedlings in all the groups were placed in a dark cupboard for a week.
- The growth of the stem was then observed.

The diagram below shows how the seedlings in each group were treated.

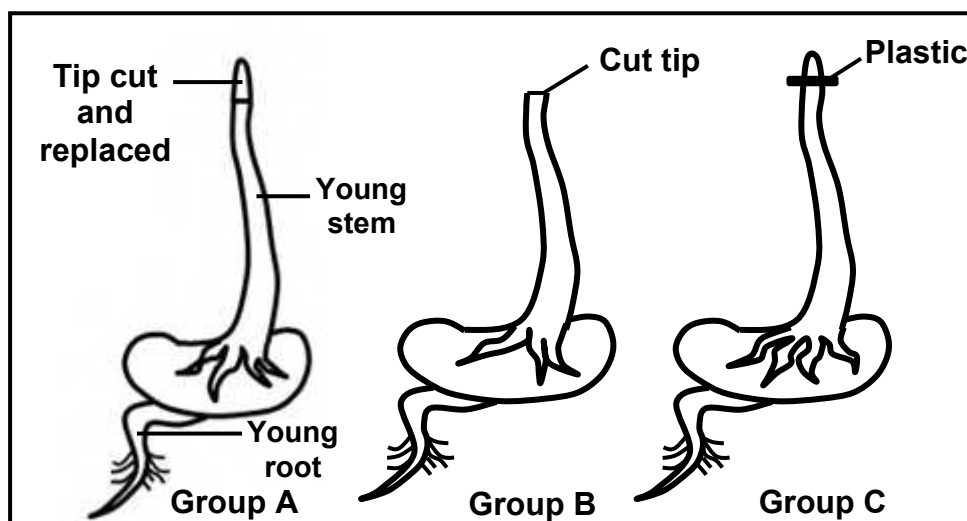

- 3.4.1 Identify the dependent variable in this investigation. (1)
- 3.4.2 Why did the learners cut the tips of the young stems? (1)
- 3.4.3 Give ONE reason why 10 bean seedlings were used in each group. (1)
- 3.4.4 Write down the LETTER(S) (**A**, **B** or **C**) of the group(s) where there will be no upward growth of the stem. (2)
- 3.4.5 Describe how auxins cause apical dominance. (3)
- 3.4.6 Name the plant hormone: (1)
- (a) Other than auxins, that promotes the germination of seeds (1)
- (b) That inhibits the germination of seeds (1)
- (10)**

3.5 Read the extract below.

The bluefin tuna, the great white shark and the bottlenose dolphin are three aquatic species that are found in the Indian Ocean.

An adult bluefin tuna releases up to 540 000 000 eggs into the water annually, while the great white shark female produces 2 to 12 offspring through ovovivipary every two years. A bottlenose dolphin female, being a mammal, is viviparous and produces one offspring every two to three years.

- 3.5.1 Name the type of fertilisation that takes place in the bottlenose dolphin. (1)
- 3.5.2 Explain how TWO of the reproductive strategies of the great white shark increase its reproductive success. (4)
- 3.5.3 Explain ONE reason why the bluefin tuna releases a large number of eggs. (2)
- (7)
- [50]

TOTAL SECTION B: 100
GRAND TOTAL: 150



basic education

Department:
Basic Education
REPUBLIC OF SOUTH AFRICA

**NATIONAL
SENIOR CERTIFICATE**

GRADE 12

LIFE SCIENCES P1

NOVEMBER 2021

MARKING GUIDELINES

MARKS: 150

These marking guidelines consist of 9 pages.

PRINCIPLES RELATED TO MARKING LIFE SCIENCES

- 1. If more information than marks allocated is given**
Stop marking when maximum marks is reached and put a wavy line and 'max' in the right-hand margin.
- 2. If, for example, three reasons are required and five are given**
Mark the first three irrespective of whether all or some are correct/ incorrect.
- 3. If whole process is given when only a part of it is required**
Read all and credit the relevant part.
- 4. If comparisons are asked for but descriptions are given**
Accept if the differences/similarities are clear.
- 5. If tabulation is required but paragraphs are given**
Candidates will lose marks for not tabulating.
- 6. If diagrams are given with annotations when descriptions are required**
Candidates will lose marks.
- 7. If flow charts are given instead of descriptions**
Candidates will lose marks.
- 8. If sequence is muddled and links do not make sense**
Where sequence and links are correct, credit. Where sequence and links are incorrect, do not credit. If sequence and links become correct again, resume credit.
- 9. Non-recognised abbreviations**
Accept if first defined in answer. If not defined, do not credit the unrecognised abbreviation but credit the rest of the answer if correct.
- 10. Wrong numbering**
If answer fits into the correct sequence of questions but the wrong number is given, it is acceptable.
- 11. If language used changes the intended meaning**
Do not accept.
- 12. Spelling errors**
If recognisable, accept the answer, provided it does not mean something else in Life Sciences or if it is out of context.



13. **If common names are given in terminology**
Accept, provided it was accepted at the national memo discussion meeting.
14. **If only the letter is asked for but only the name is given (and vice versa)**
Do not credit.
15. **If units are not given in measurements**
Candidates will lose marks. Memorandum will allocate marks for units separately.
16. **Be sensitive to the sense of an answer, which may be stated in a different way.**
17. **Caption**
All illustrations (diagrams, graphs, tables, etc.) must have a caption.
18. **Code-switching of official languages (terms and concepts)**
A single word or two that appear(s) in any official language other than the learners' assessment language used to the greatest extent in his/her answers should be credited if it is correct. A marker that is proficient in the relevant official language should be consulted. This is applicable to all official languages.
19. **Changes to the memorandum**
No changes must be made to the memoranda without consulting the provincial internal moderator who in turn will consult with the national internal moderator (and the Umalusi moderators where necessary).
20. **Official memoranda**
Only memoranda bearing the signatures of the national internal moderator and the Umalusi moderators and distributed by the National Department of Basic Education via the provinces must be used.

SECTION A

QUESTION 1



| | | | | |
|-----|-------|------------------------------|---------|-------------|
| 1.1 | 1.1.1 | C✓✓ | | |
| | 1.1.2 | B✓✓ | | |
| | 1.1.3 | D✓✓ | | |
| | 1.1.4 | C✓✓ | | |
| | 1.1.5 | A✓✓ | | |
| | 1.1.6 | B✓✓ | | |
| | 1.1.7 | C✓✓ | | |
| | 1.1.8 | B✓✓ | | |
| | 1.1.9 | A✓✓ | (9 x 2) | (18) |
| 1.2 | 1.2.1 | Ovulation✓ | | |
| | 1.2.2 | Synapse✓ | | |
| | 1.2.3 | Gestation✓ | | |
| | 1.2.4 | Tropism✓ | | |
| | 1.2.5 | Precocial✓ development | | |
| | 1.2.6 | Allantois✓ | | |
| | 1.2.7 | Seminiferous✓ tubules | | |
| | 1.2.8 | Abscisic acid✓ | (8 x 1) | (8) |
| 1.3 | 1.3.1 | Both A and B✓✓ | | |
| | 1.3.2 | A only✓✓ | | |
| | 1.3.3 | B only✓✓ | (3 x 2) | (6) |
| 1.4 | 1.4.1 | (a) Vas deferens✓/sperm duct | | (1) |
| | | (b) Scrotum✓ | | (1) |
| | | (c) Penis✓ | | (1) |
| | 1.4.2 | (a) D✓ Epididymis✓ | | (2) |
| | | (b) G✓ Urethra✓ | | (2) |
| | | (c) E✓ Testis✓ | | (2) |
| | 1.4.3 | A✓ B✓ E✓ | Any | (2) |
| | | (Mark first TWO only) | | (11) |
| 1.5 | 1.5.1 | (a) Cytoplasm✓ | | (1) |
| | | (b) Jelly layer✓ | | (1) |
| | | (c) Tail✓/ Flagellum | | (1) |
| | 1.5.2 | Mitochondrion✓ | | (1) |
| | 1.5.3 | A✓ and F✓ | | (2) |
| | | (Mark first TWO only) | | |
| | 1.5.4 | Oogenesis✓ | | (1) |
| | | | | (7) |

TOTAL SECTION A: 50

SECTION B

QUESTION 2

- 2.1 2.1.1 Motor✓ /efferent neuron (1)
- 2.1.2 C → B → A✓✓ (2)
(Must be in the correct sequence)
- 2.1.3 - Impulses will be transmitted faster in neuron 1✓✓/ slower in neuron 2
- because of the presence of a myelin sheath in neuron 1✓/ absence of a myelin sheath in neuron 2 (3)
- 2.1.4 - Impulses from the receptor✓/sensory neuron
- will be transmitted to the central nervous system✓ but
- the impulse will not reach the effector✓ (3)
(9)
- 2.2 2.2.1 Choroid✓ (1)
- 2.2.2 - Holds the lens in position✓
- Connects the lens to the ciliary body✓
- Plays a role in accommodation✓ Any (1)
(Mark first ONE only)
- 2.2.3 (D/the yellow spot) has the highest concentration of cones✓ (1)
- 2.2.4 - Part B/sclera is opaque✓✓/does not allow light to pass through/ white
- part F/lens is transparent✓✓/allows light to pass into the eye
OR
- Part B/sclera is non-elastic✓✓/maintains the shape of the eye
- part F/lens is elastic✓✓/able to change its shape (4)
(Mark first ONE only)
- 2.2.5 - The circular muscles relax✓
- The radial muscles contract✓
- causing the pupil to dilate✓ (3)
- 2.2.6 - The lenses in the spectacles will refract the light rays✓
- The lens of the eye also refracts✓ the light rays
- The light rays will therefore be focused in front of the retina✓ (3)
(13)

- 2.3 2.3.1 Uterus✓ (1)
- 2.3.2 - The thickened layer may cause an obstruction✓/blockage
- which may prevent the passage of gametes✓
- preventing fertilisation✓ from taking place
- OR**
- 2.3.2 - The thickened layer may cause an obstruction✓/blockage
- which may prevent the embryo from reaching the uterus✓/
implantation could occur in the Fallopian tube
- which may lead to the death of the embryo✓/rupturing of the
fallopian tube/miscarriage (3)
- 2.3.3 - A high concentration of progesterone✓
- inhibits the pituitary gland from secreting FSH✓
- Without FSH a follicle will not develop✓ in the ovary
- Therefore, oestrogen will not be secreted✓ (4)
- (8)**
- 2.4 - The pinna of the ear traps sound waves✓
- The auditory canal directs the sound waves to the tympanic membrane✓
- causing the tympanic membrane to vibrate✓
- which causes the ossicles to vibrate✓ and
- pass the vibrations to the oval window✓/amplify the vibrations
- (Pressure) waves are set up in the inner ear✓/perilymph/endolymph
- The organ of Corti is stimulated✓
- and converts the stimuli into impulses✓
- which are transmitted by the auditory nerve✓
- to the cerebrum✓ for interpretation
- Any (7)



| | | | | |
|-----|-------|---|-----|-------------|
| 2.5 | 2.5.1 | Chorion✓ | | (1) |
| | 2.5.2 | - Acts as a shock absorber✓ - It prevents desiccation✓/dehydration - It helps to keep the temperature within a narrow range✓ - It facilitates free movement✓ of the foetus | Any | (2) |
| | | (Mark first TWO only) | | |
| | 2.5.3 | - The zygote divides by mitosis✓ - to form a (solid) ball of cells✓ - called the morula✓ - which develops into a hollow ball of cells✓ - called the blastula✓/blastocyst | Any | (4) |
| | 2.5.4 | - Acts as a micro-filter✓/protect against pathogens - Removal of harmful metabolic waste✓ - Produces antibodies✓ - Maintains the endometrium✓ | Any | (2) |
| | | (Mark first TWO only) | | |
| | 2.5.5 | Umbilical vein✓ | | (1) |
| | 2.5.6 | - In humans the developing foetus receives nutrients from the mother's✓ blood - via the placenta✓/umbilical vein - In oviparous organisms the developing embryo receives nutrients from the yolk✓/albumen | Any | (3) |
| | | | | (13) |
| | | | | [50] |

QUESTION 3

- 3.1 3.1.1 Cerebellum✓ (1)
- 3.1.2 - Connects the two hemispheres of the brain✓
- Allows for communication between the two hemispheres of the brain✓ Any (1)
- (Mark first ONE only)**
- 3.1.3 D✓ Cerebrum✓ (2)
- 3.1.4 (a) Adrenalin✓ (1)
- (b) - More air/oxygen will be inhaled✓
- Blood will be pumped faster✓
- therefore, transporting more oxygen and glucose✓ to the skeletal muscles
- which will increase the rate of cellular respiration✓/metabolism (4)
- (c) - Part B/the medulla oblongata is stimulated✓
- and sends impulses to the heart✓and to
- the breathing muscles✓/ intercostal muscles and diaphragm
- More blood is transported to the lungs✓
- and the carbon dioxide is exhaled faster✓ (4)
- and the carbon dioxide levels return to normal✓ Any **(13)**
- 3.2 3.2.1 50✓°C (1)
- 3.2.2 As the temperature increases the average rate of blood-flow to the skin increases✓✓ (2)
- 3.2.3 $\left. \frac{11-4}{4} \right\} \checkmark \times 100 \checkmark = 175 \checkmark \% \quad \text{OR} \quad \left. \frac{7}{4} \right\} \checkmark \times 100 \checkmark = 175 \checkmark \%$ (3)
- 3.2.4 - As the temperature increases✓ from 20 °C to 45 °C
- vasodilation occurs✓/blood vessels dilate
- to increase the rate of blood flow✓ /more blood flows to the skin
- so that more heat✓/ sweat can be lost (4)
- 3.2.5 - Less blood flows to the skin✓ at low temperatures
- Less oxygen✓/nutrients reach the cells of the tissue and the cells may die
- OR**
- Less blood flows to the skin✓ at low temperatures
- More carbon dioxide✓/waste products accumulate in the cells of the tissue and the cells may die (2)
(12)

| | | | | |
|-----|-------|--|-------------------------|----------------------------------|
| 3.3 | 3.3.1 | - The pituitary gland✓ is stimulated - to secrete less TSH✓ - Low TSH levels causes the thyroid gland✓ - to secrete less thyroxin✓ - Thyroxin levels return to normal✓ | | (5) |
| | 3.3.2 | - The rate of metabolism/respiration in the body decreases✓ - Less glucose will be broken down✓ - and more glucose will be converted and stored as fat✓/glycogen | | (3) (8) |
| 3.4 | 3.4.1 | Stem growth✓ | | (1) |
| | 3.4.2 | - To remove the source of auxins✓ - The tip produces auxins✓ | Any | (1) |
| | 3.4.3 | To increase the reliability✓/validity of the results | | (1) |
| | 3.4.4 | B✓ and C✓ | | (2) |
| | 3.4.5 | - The presence of auxins✓ in the tip of the stem - stimulate upward growth✓ - and inhibit development of lateral branches✓ | | (3) |
| | 3.4.6 | (a) Gibberellins✓ (b) Absciscic acid✓ | | (1) (1) (10) |
| 3.5 | 3.5.1 | Internal✓ fertilisation | | (1) |
| | 3.5.2 | - Internal fertilisation✓ increases the chances of fertilisation✓ - Ovovivipary✓/ eggs retained inside the female's body where they are protected✓ (Mark first TWO only) | (2 x 2) | (4) |
| | 3.5.3 | - To increase the chances of fertilisation✓/ the survival of the eggs/ number of offspring - As eggs may be lost to predators✓/environmental factors etc - Since there is external fertilisation✓ | Any | (2) (7) [50] |
| | | | TOTAL SECTION B: | 100 |
| | | | GRAND TOTAL: | 150 |